

Indian Institute of Carpet Technology (IICT), Bhadohi-221401

(Proposed EFC/SFC Phase-III for five years i.e. 2016-17 to 2020-21)

1. Project Identification:

1.1 Title of the project/scheme:

Documentation for formulation of Phase-III EFC/SFC for expansion of **Indian Institute of Carpet Technology, Bhadohi, U.P.**

1.2 Name of the sponsoring agency (Ministry/Department/Autonomous Body/ Central PSE):

Government of India, Ministry of Textiles, Office of the Development Commissioner (Handicrafts)

1.3 Proposed duration of the Project :

2016-17 to 2020-21 (five years)

1.4 Total Cost of the project over the proposed duration :

Rs.68.42 Crore (Rupees Sixty Eight crore & Forty Two lakhs)

2. Project Status:

2.1 Please indicate which category the project belongs to:

- (a) Continuing scheme from past plan periods and included in current plan period.
- (b) New Plan Scheme included in the current Plan period
- (c) New Plan scheme not included in the current Plan period
- (d) RCE proposal

The scheme belongs to category 2.1 (a)

2.2 If project pertains to category 2.1 (a), Please summarize the benefits already accrued and expenditure already incurred along with an independent evaluation of the past performance of the project scheme:

Indian Institute of Carpet Technology (IICT) has become academically functional with effect from 01.11.2001 exactly within the stipulated targeted schedule. The functionality marked with the initiation of first ever class room activity for the 1st semester B. Tech. Students in the branch of Carpet & Textile Technology (CTT) duly **approved by All India Council for Technical Education (AICTE) and affiliated to the then Dr. A.P.J. Abudl Kalam Technical University formally Uttar Pradesh Technical University.**

Thereafter, IICT decided its portfolios through which service to the industry and stakeholders duly provided. The descriptions, achievements etc. are available through enclosed documents. However, the summary of utilization of HRD is as under

Utilization of B. Tech. Graduates: IICT Bhadohi is conducting B.Tech. Course in Carpet & Textile Technology from the year 2001 and **11 Batches** have come out successfully with a total of 373 graduates in the related trade. After completion of their course, the students are supposed to join any reputed organization related to Textiles/Carpets/Wool Industry. In this regard, the Placement cell of the Institute is dedicatedly involved for providing jobs to all outgoing students well before completion of their course. In addition to the same, some students opt for higher education like M.Tech/MBA/Fashion Tech. from the leading Institutes. An overall report of B.Tech. Graduates passed out from IICT Bhadohi are as under:-

1. All most 80-85% of the passed out graduates are serving leading Textile and Carpet Industry, the names of few are as under:-
M/s Vardhaman Textile Ltd, Ludhiana, Nahar group of companies, Ludhiana, Alps Industries, Meerut, Alok Industries, Silvasa, Gujrat Ambuja, Gujrat, Raymond India, Valsad, RSWM, Bhilwada, Paliwal exports Panipat, Shahi exports Faridabad, Orient Carpets Bhadohi, OBEETEE Pvt. Ltd, Gopiganj, Raj overseas, Panipat, ABC Carpet, Mirzapur, Wires & Fabrics, Kolkata and many more.
2. All most 10-15% of the passed out graduates are opting higher education from world's leading Institutions, the names of few are as under:-
IIT Delhi, IIT Kanpur, IIT Bombay, IIT Kharagpur, NITIE Bombay, UDCT Bombay, NIFT Delhi, NIFT Bangalore etc.
3. Rest 0-5% of the passed out graduates are either self employed or chosen other Industry like Banking, Software etc.

Utilization of other trainees:

Under various schemes IICT has created artisans in the form of skill development and or upgradation. The list of trainees has been sent to CEPC, AICMA, EUPEA and MCMA for utilization by potential employer. The information on availability of trained unemployed carpet weavers to the tune of 2000 which include 1200 females weavers, of ages 20-40. Interested employer may contact M/s Unnayan Sansthan, Chunar. Some glimpses of female weavers receiving training are reproduced below-



Fig. 1
Female weavers under training at IICT, Bhadohi

Details of year wise grant received and grant utilized for SFC of Phase-II:

(Rs. In lakhs)

Year	Grant Released		Grant Utilized	
	Non-recurring	Recurring	Non-recurring	Recurring
2005-06	130.00	80.00	Nil	Nil
2006-07	150.61	163.77	Nil	169.00
2007-08	Nil	Nil	14.88	157.21
2008-09	127.72	335.00	51.16	168.36
2009-10	Nil	Nil	234.35	205.39
2010-11	82.79	356.00	54.84	213.09
2011-12	42.41	256.36	174.57	222.75
2012-13	180.00	100.00	30.65	220.80
2013-14	Nil	Nil	54.09	--
2014-15	Nil	Nil	19.91	--
2015-16 (4/2015 to 16-11-2015)	265.56	65.47	156.00	--
Total	979.09	1356.60	790.45	1356.60

Allocation of SFC Phase-II:

(Rs. in lakhs)

Particulars	Sanctioned Amount	Released Amount	Spent	Fund available in SFC-II
(1)	(2)	(3)	(4)	(5) 2-3
Non-Recurring	1143.00	979.09	790.45	163.91
Recurring	1356.60	1356.00	1356.60	--
Total	2499.60	2335.69	2147.05	163.91

The need for further expansion of IICT has been felt by all corners including industry & university (**copy of resolution of Executive Committee of IICT is enclosed – Annexure-I**)

On the issue of further expansion of IICT and preparation of EFC/SFC-III, & subsequent engagement notice to M/s. LICI, Kanpur as well as minutes of the internal meeting involving IICT staff members are annexed (**Minutes of meeting IICT staffs on Phase-III-Annexure-II**)

On the above background IICT provided all available inputs in well-documented form. M/s LICI, Kanpur then engaged and approved consultant, who in close coordination with all concerned verified this document with respect to the civil work of the proposal including cost estimates etc and issued forwarding letter cum endorsement in the form of email (**copy of LIC email on NR BE & Master Plan enclosed-Annexure-III**) as independent/ body for onward submission to the Office of Development Commissioner (Handicrafts) for subsequent action.

In addition, as per direction received from higher authorities- A.S.& F.A., Development Commissioner (HC), Divisional Commissioner, Vindhyachal Mandal etc., to attain the objective of Swachh Bharat Mission, Greening, Rainwater Harvesting, Solar Energy Generation etc. & emerging needs, the additional estimated cost amounting to Rs.448.46Lakhs has been included in the proposed Non-recurring Expenditure plan under EFC Phase-III.

INTRODUCTION IN RETROSPECT:

The institute was originally sanctioned Rs.18.04 crore to meet non recurring and recurring expenditure in Phase-I of the project. Thereafter, high power Committee met at Udyog Bhawan on 13.03.2006 and 02.02.2007 chaired by the then Secretary (Textiles) and The discussion was initiated observing success of the Phase-I and after detailed discussion the EFC approved the proposed expansion of the institute in the Phase-II with certain stipulations. (**Minutes of the meeting enclosed - Annexure-IV**). It is therefore pertinent to provide a status of implementation of the various components of the project approved by EFC dated 02.02.2007 as under.

Status of implementation of the various components of the project approved by EFC dated 02.02.2007

Sr. No.	Minute No.	
1.	Minute No. 1 <ul style="list-style-type: none">• A fresh EFC Meeting over 13.03.2006 was to be convened.	Accordingly a fresh meeting was convened on 02.02.2007

Sr. No.	Minute No.	
	<p>Minute No. 2</p> <ul style="list-style-type: none"> • In order to extend and update the available infrastructure including faculty need has been felt to introduce Home Textile Technology (HTT) and Textile Design Technology (TDT) as new subjects • The aggregate expenditure proposed on expansion on Phase II after year 2009-10 has been Rs. 24.99 crore (11.43 for NR and 13.56 for Recurring) 	<p>Institute has inducted HTT, TDT and Advances in Carpet Technology (ACT) as new disciplines in an integrated manner in the existing B.Tech Course with an intake of 60 students per batch.</p> <p>The project has undergone another SFC under the chairmanship of the then Secretary (Textiles) on 15.11.2011 with regard to the proposed modified expansion of IICT, Bhadohi (Phase-II) and the term of the project has been extended till 2015-16 within the original approved cost and certain re-appropriations.</p>
	<p>Minute No. 3</p> <p>Advisor (PAMD) felt that it was necessary to evaluated as to whether students passing out from the institution were finding employment in the market.</p>	<ol style="list-style-type: none"> 1. All most 80-85% of the passed out graduates are serving leading Textile and Carpet Industry, the names of few are as under:- M/s Vardhaman Textile Ltd, Ludhiana, Nahar group of companies, Ludhiana, Alps Industries, Meerut, Alok Industries, Silvasa, Gujrat Ambuja, Gujrat, Raymond India, Valsad, RSWM, Bhilwada, Paliwal exports Panipat, Shahi exports Faridabad, Orient Carpets Bhadohi, OBEETEE Pvt. Ltd, Gopiganj, Raj overseas, Panipat, ABC Carpet, Mirzapur, Wires & Fabrics, Kolkata and many more. 2. All most 10-15% of the passed out graduates are opting higher education from world's leading Institutions, the names of few are as under:- IIT Delhi, IIT Kanpur, IIT Bombay,

Sr. No.	Minute No.	
		<p>IIT Kharagpur, NITIE Bombay, UDCT Bombay, NIFT Delhi, NIFT Bangalore etc.</p> <p>3. Rest 0-5% of the passed out graduates are either self employed or chosen other Industry like Banking, Software etc.</p>
	<p>Minute No. 4 Concerned expressed 'Location of Phase-II away from the Phase-I building'</p>	<p>In the reply , the then DC(HC) said that this have to be done because no land was available near Phase-I.</p>
	<p>Minute No. 5 Stipulations</p> <ol style="list-style-type: none"> 1. The total cost of expansion would be Rs. 24.99 crore (11.43 for NR and 13.56 for Recurring) 2. IICT should initially consolidate the present intake of 60 students for two years, However, more numbers of modular courses on the line of modular employable skills (MES) for a duration upto 6 months or so covering Computer Applications, Information Technology, Management/Marketing/Entrepreneurship, Merchandising etc, relevant to the promotion of wool, carpet and textile industry shall be introduced by involving participation from trade and industry also. 3. Presentably IICT may continue with its increased 	<p>It is maintained. However, the project has undergone another SFC under the chairmanship of the then Secretary (Textiles) on 15.11.2011 with regard to the proposed modified expansion of IICT, Bhadohi (Phase-II) and the term of the project has been extended till 2015-16 within the original approved cost and certain re-appropriations (copy enclosed)</p> <p>Institute has consolidated the present intake of 60 students till date. As regards modular courses institute is running similar courses. In implementation the Integrated Skill Development Scheme (ISDS) and Compressive Handicraft Cluster Development Scheme (Plan) of D.C (Handicrafts) of Ministry of Textiles, G.O.I have been integrated. The participation from trade and industry have also been ensured.</p> <p>IICT to continue its present activity and</p>

Sr. No.	Minute No.	
	<p>intake of 60 students in CTT duly integrated with HTT & TDT. However, further increase in the number of students would depend upon the need of the industry over a period of two years.</p> <p>4. For creation of proposed 26 posts, a proposal may be sent to JS (Pers). However, the institute should also introduce the system of engaging guest faculty wherever feasible.</p> <p>5. An evaluation of the course context, students placement & impact on the industry should be done every 2 years by an independent agency</p>	<p>Instead of further increase in intake of 60 students in CTT, some new disciplin like M.Tech in Carpet & Textile Management (CTM) may be added as are being proposed to be introduced through the proposed Phase-III expansion. Continuation of present activity / Continuation of present activity with additional activity proposed.</p> <p>Requisition has been placed to the office of D.C(HC) [copy enclosed]. Institute has already introduced the system of engaging guest faculty as well out source any person /agency for such services like gardening, sweeping, Security or secretarial serves etc.</p> <p>The evaluation is being done by independent bodies like UPTU, the affiliated University; AICTE the statutory approval body; NBA another statutory approval body; The Textiles Institute (Manchester, UK) International approval body; IGNOU-AICTE-UGC joint committee ; for respective teaching /training activity and Integrated Quality Systems like ISO-9001 and ISO 17025 for Institute as a whole and laboratory in particular respectively.</p>

The schedule of implementation of the project components left unimplemented, if any:

The project has undergone certain changes as evident from compliance note prepared on Status of Implementation of the Various Components of the Project approved by SFC 02.02.2007 and approved through further SFC under the chairmanship of then then Secretary (Textiles) on 15.11.2011. However, the highlighting changes are as under:

a. Term of Project:

It has been extended from 5 years to 10 years i.e. upto 2015-16

b. Re-appropriate of fund under Non Recurring head

Re appropriation of fund Rs. 677 lakhs under sub head – Civil Electrical and Miscellaneous covering hostel building, lecture theatre /workshop and staffs accommodation.

c. Re-appropriate of fund under Recurring head

Re appropriation of fund Rs. 313.60 lakhs under sub head –Miscellaneous contingency covering contractual utility services petrol and diesel, communication and telephone, extension activities, membership fees and other contingencies

BACKGROUND:

An overview:

Indian Institute of Carpet Technology (IICT), Bhadohi, set up of Ministry of Textiles, Government of India under the aegis of Development Commissioner (Handicrafts) needs no formal introduction as it has proven itself for what it was established. It was felt by Government of India in 70's that there should be some institute/training centre within the periphery of India's highest handmade carpet producing belt. The Institute, which could provide desired support in development of carpet and allied textile industry. Keeping this into view, the location of the Institute is made such that it is 35 km from Mirzapur, 15 km from Aurai and 20km from Gopiganj; all these areas are well recognized in the global map for the production of Hand made Carpets. The beginning of the institute was made in 28th November 1998, through a Registered society and became truly functional with effect from 1st November 2001 by starting a B.Tech. course in Carpet & Textile Technology. Hence, IICT family celebrates this day as “**INSTITUTE DAY**” on 1st November of every year. However, the Institute was formally dedicated to the nation on 11th May 2002 by the then Hon'ble Minister of Textiles in presence of other dignitaries and office bearers. The course is unique in the sense that the students get an opportunity to learn the technicalities involved in manufacturing of a carpet and a textile good as well, in a four year duration.

IICT Bhadohi works under following 4 portfolios:-

- a. Human Resource Development (HRD)
- b. Design Creation and Development (DCD)
- c. Research & Development (R&D)
- d. Technical Service Support to Industry (TSI)

a. **HRD:** Under HRD portfolio, the Institute runs B. Tech. course related with Carpet and Textile Trade. So far all B.Tech. graduates seeking employment are placed while some are

either self employed or opted for higher education in institute of repute like IIT's NIT's, NITIE, ISM etc. Under B.Tech programme in Carpet & Textile Technology trade, 179 students have already passed out so far and are serving Carpet, Textile & related industry.

At present the total intake in B.Tech. is 60 integrating Home Textile Technology(HTT) & Textile Design Technology (TDT) as specialization in addition to existing Carpet and Textile Technology (CTT), where in 20 students in each category shall be specialized.

The distance learning programme has recently drawn attraction from various parts of the country and study centres are being created. Other than this, some short term courses sponsored by various agencies (such as government and Industry) are also run to provide trained Human resource to the society. The integrated skill development scheme (ISDS) of Ministry of Textiles is one such kind of scheme, which has been sanctioned to IICT to create supervisor /master trainer to the tune of 2400 persons over a period of 5 years. The scheme has been launched to initiate training on carpet weaving, carpet yarn dyeing, computer and IT application for carpet industry , carpet yarn spinning, carpet designing etc related modules pertain to carpet manufacturing covering 117 trainees besides 106 persons to be trained in Malda Carpet Cluster of West Bengal duly supported by Govt. of West Bengal. A training program under Mega Cluster Scheme of Ministry of Textiles, G.O.I. is being started to train 5000 crafts person in coming three years covering Bhadohi-Mirzapur carpet belt.

Table 1. Year-wise Description of B. Tech. students & their Placement status

Sr. No.	Financial Year	No. of outgoing B. Tech. Students	Placement of Students
1	2001 - 2002	Commence of B. Tech Course	-----
2	2002 - 2003	-----	-----
3	2003 - 2004	-----	-----
4	2004 - 2005	19	100 %
5	2005 - 2006	12	100 %
6	2006 - 2007	16	100 %
7	2007 - 2008	12	100 %
8	2008 - 2009	33	100 %
9	2009 -2010	43	100 %
10	2010 - 2011	44	100 %
11	2011 - 2012	24	100 %
12	2012-2013	54	100%
13	2013 - 2014	48	100%
14	2014-2015	68	100%
Total		373	

Year wise details of B.Tech. Students:

Position of 1 st year Admission through AIEEE/JEE/Direct			Lateral Entry to 2 nd year Admission position		Position of passed out students	
Year	Intake	No. of enrolled students	Intake	No. Enrolled students	Year	Passed out Students (Enrolled)
2001	20	19	--	--	2001	Nil
2002	20	16	1	1	2002	Nil
2003	20	19	--	--	2003	Nil
2004	20	19	--	--	2004	Nil
2005	30	30	3	3	2005	19 (19)
2006	60	48	--	--	2006	12 (16)
2007	60	44	6	5	2007	16 (19)
2008	60	24	6	3	2008	12 (19)
2009	60	54	6+4	10	2009	33 (30)
2010	60	57	6+15	21	2010	43 (48)
2011	60	60	6	6	2011	44 (44)
2012	60	59	12	12	2012	24 (24)
2013	60	60	12	12	2013	54 (54)
2014	60	60	12	12	2014	48 (57)
2015	60	59	12	12	2015	68(71)
Total	710	628*	101	97	Total	373** (401)

***Capacity utilization @88.45%**

**** Retention of enrolled students @93.01%**

Table 2. Details of running Training Programs as on date:

Sr. No.	Nature of course	Status
1.	Short term training programmes - ISDS	<p>1138 trainees have been trained in following modules:</p> <p>CAD - 405 Trainees completed the programme.</p> <p>Computer & Mgt- 199 Trainees completed in the programme.</p> <p>Dyeing- 95 Trainees completed in the programme</p> <p>Spinning of Woolen Yarn- 20 Trainees completed in the programme</p> <p>Washing & Finishing- 80 Trainees completed in the programme</p> <p>Carpet weaving for hand- knotted / hand tufted/ loom made - 183</p> <p>West Bengal Govt. - 156 Trainees enrolled in the programme</p>
2	Imparting skill up-gradation to 5000 carpet weavers /artisans of Bhadohi-Mirzapur under Comprehensive Handicrafts Cluster Development Scheme (Plan)	<ul style="list-style-type: none"> • 2050 Trainees have been trained. • Details have been communicated to CEPC, AICMA, Technopack all concern for utilization of their competency derived.
3	Industry-driven special courses & IDLP Packages	54 enrolled

b. **DCD:** Under DCD portfolio, creation of new designs, modification and development of motifs related to carpet and textile is made using CAD softwares like Autotex and Nedgraphics. Design solution through Design Bank has been introduced which is gaining lot of popularity among Industry people. The bank is having more than 7000 designs from which around 500 designs have been utilized by industry for commercial purpose.

c. **R&D:** In R&D front, attempt is made to commercialize the products/developments/ technologies invented by the Institute. Some of the outcome of the R & D portfolio are Snehabha

Carpet Backing, India Knot, Natural coloration, Natural fiber carpet, Cross Bar Horizontal Loom, CARPCOST software and many more.

d. **TSI:** TSI portfolio is concerned about the testing, certification, trouble shooting and consultancy work related with the trade. It is proud to say that the testing laboratory of IICT Bhadohi is accredited to NABL conforming ISO 17025.

Table 3. Description of the Testing Services conducted by IICT Laboratories

Sl. No.	Financial Year	No. of Testing Services Conducted
1	2005 - 2006	1441
2	2006 - 2007	1815
3	2007 - 2008	1968
4	2008 - 2009	2002
5	2009 -2010	1377
6	2010 - 2011	1128
7	2011 - 2012	1012
8	2012 - 2013	1202
9	2013 - 2014	1073
10	2014-2015	1509
11	2015-16 till 26-03-2016	1007

To develop an interface with industry, a forum “Kaleen Bandhu” is working under which various Kaleen and related industries are members. Regular meetings are held where institute-industry works together to discuss and resolve the problems of industry. These members get preferential treatment from IICT to boost their trade.

Being an academic institute, IICT understands its duty to provide information and literature related with the new developments going on worldwide related with the trade. In this regard, many publications including books written by the Director of the institute are offered to the Industry, which are being useful for the Stakeholders. Similarly, a good number of patents and Trade marks are also in the credit of the Institute.

IICT Bhadohi has been awarded UPTU Excellence Award twice as a star performer. The students of the institute have received Gold and Silver medals from the university in their academics.

Time to time, Extra ordinary Personalities from society, administration, press/media and political background have visited the institute. Motivational words of appreciation are received from these dignitaries, which inspires the whole IICT family in taking new initiatives.

The Director of the Institute, Prof (Dr) KK Goswami, who is also the founder Director has a vision to see the Institute as a Centre of Excellence and a consistent Endeavour is made by him and his dedicated team with due guidance of Chairman & Vice-Chairperson to reach the Institute to comply with the requirements of international standards for all its portfolios.

Over a decade, IICT has contributed through its established portfolios particularly in HRD & R&D to a great extent to meet the existing gap. Thus IICT is committed to support the trade to take it to new heights in all relevant fronts.

Journey of IICT since 2002:

IICT was dedicated to the Nation by the then Hon'ble Minister of Textiles, Govt. of India in presence of Hon'ble Minister of SSI, Govt. of UP on 11th May 2002 and international collaboration was established (Fig.1). Coveted Awards bagged are depicted in Fig 2 & 3. Honlbe Minister of State for Textile interacted with IICT students, faculty & industry in presence of DC (Handicrafts), Chairman, IICT & Director, IICT Fig. 4. Unveiling of ISDS booklet by launched by IICT (Fig.5). A team of The Institution of Engineers, Varanasi Local Centre, visited IICT for interaction (Fig.6)

JOURNE OF IICT IN PICTURES



Fig. 1 Unveiling of the Dedication Stone by the then Hon'ble Minister of Textiles, in presence of all dignitaries, invitees, students and medias personnel's



Mr. Ankit Kumar & Ms Shruti students of IICT are receiving Gold and Silver Medal for year 2010 respectively from His Excellency, Governor of UP, Chancellor, GBTU in presence of Ex-Chairman, ISRO, Dr. G. Madhavan Nair & other dignitaries

Award bagged by IICT



Indian Institute Of Carpet Technology (IICT) Bhadohi, has been awarded UPTU Excellence award as a Star Performer. The award was received by Vice Chairman Dr. Sandeep Srivastava & Prof(Dr) K. K. Goswami, Director, IICT, from H. E. Governor of U.P. & Chancellor of U.P.T.U. in a celebration on the eve of inauguration of NOIDA Campus of UPTU on 14.2.2008. Shri Sanjay Agarwal, IAS, DC(Handicraft), Chairman IICT, Dr. Sandeep Srivastava ADC(Handicraft), Vice chairman IICT congratulated Prof(Dr) K.K.Goswami Director IICT & his team for their effort in achieving this rare height.

Fig. 2, Fig. 3

Fig. 4

Hon'ble Minister of State for Textiles flanked by Development Commissioner (Handicrafts),MOT,GOI (RHS) and Director IICT (LHS) addressing the IICT faculty, staffs, students and Industry



Fig. 5

Hon'ble Union Minister of Textile, Shri Anand Sharma, Smt Rita Menon, IAS thethen Secretary (T), MOT & Shri S.S.Gupta, IAS Development Commissioner (Handicrafts),MOT unveiling the ISDS Booklet launched by IICT,Bhadohi



Fig. 6

A team of Varanasi Local Centre, Institution of Engineers (I), Varanasi visited the institute for interaction with students, faculty, staffs & industry



Fig. 7

Shri Satyajeet Thakur thethen Divisonal Commissioner Mirzapur lighted the lamp during one of the students cultural programme in presence of representatives of carpet industry.



Fig. 8

Mrs. Satyajeet Thakur & Satyajeet Thakur unveiling students magazine “tanabana” in one of the cultural programme of the decade in presence of Mr. Abdul Hadi the then Hony.Secretary ,AICMA representing carpet industry.



Fig. 9

Mr. Akhilesh Maurya (2012 batch) one of the brilliant students of IICT presently doing M.Tech from IIT Delhi is receiving compliment on the occasion of farewell party to the outgoing batch of 2012.



Fig. 10

The then district magistrate Mrs. Kanchan Verma is encouraging the students by means of unveiling students magazine “tanabana” in one of the cultural event of the decade



Fig. 11

IICT students performing yoga as a co-cultural activity in institutional programme.



Fig. 12

Industry invitees enjoying the cultural programme along with the students of IICT



Fig. 13

Students are enjoying the facility of new academic block created under phase II expansion project of the IICT



Fig. 14

M/s V.K.Sinha & S.K.Sinha Representative of CEPC & AICMA respectively are actively participating in prize distribution ceremony.



Fig. 15

A glimpse of green IICT through continuous endeavor of plantation



Fig. 16
Final year students of IICT ready to serve industry with effect from July 2013.
Potential carpet industrialists may contact them and or Training and Placement Officer.



Fig. 17
Faculty and students are enjoying together in annual sports meet.



*Fig. 18
Winner team of sports activities 2011*



*Fig. 19
M/s Bholanath Baranwal, R.K.Bothra and Shahid Hussain representing Carpet industry motivating one of the brilliant student of IICT in present of Director, IICT.*



Fig. 20

Prof.Kripa Shanker , Hon'ble Vice chancellor of GBTU, grace the occasion of institute day,1st Nov-2011 to motivate IICT family for academic excellence.



Fig. 21

Students & invitees are enjoying the cultural programme in the form of song sung by Professor cum consultant of IICT B.D.Dixit.



Fig. 22

Shri Satyajeet Thakur, IAS the then Divisional Commissioner, Mirzapur discussing with M/s Avinath Baranwal, Virendra Roy, Abdul Hadi and Surendra Baranwal representing carpet industry while Director IICT was present.

Table 1



Fig. 23

Plantation by HMOT Dr. K.S.Rao, Shri S.S.Gupta, IAS DC(HC), Chairman, IICT & Shri Lalitesh Pati Tripathi, MLA, Marihan



Unveiling of Placards containing Role, Achievement etc of IICT by HMOT



HMOT being briefed by Director IICT about the placards containing Role, Achievement etc of IICT unveiled by him

Fig. 24 & 25



Inspection of Carpet Testing Lab equipments by HMOT & DC(HC), Chairman, IICT



**Inspection of Carpet Testing Lab equipments by HMOT & DC(HC), Chairman, IICT
Fig. 26 & 27**



Director, IICT presented a book entitled “Process Control in Carpet Manufacturing” authored by him to HMOT



Display of Design Bank to HMOT

Fig. 28 & 29



Inspection of Looms by HMOT developed by IICT
Fig. 30 & 31

मंत्री ने लिया आइआइसीटी का जायजा

- प्रशिक्षण कार्यक्रम को विस्तार देने पर बल
- संस्थान के प्रयासों की सराहना, मदद का आश्वासन

भदोही : केंद्रीय कपड़ा मंत्री डा. केएस राव ने रविवार को भारतीय कालीन प्रौद्योगिकी संस्थान (आईआईसीटी) का जायजा लिया। इस दौरान संस्थान द्वारा कालीन उद्योग के विकास के संचालित किए जा रहे विभिन्न तकनीक से उन्हें अवगत कराया गया।

कपड़ा मंत्री वाराणसी से सीधे इंदिरा गिला स्थित संस्थान पहुंचे। पहले इंतजार कर रहे संस्थान के निदेशक डा. केके गोस्वामी सहित कर्मचारियों ने उनका गार्मजोशी से स्वागत किया। इस दौरान संस्थान द्वारा विकसित तकनीक के बारे में श्री राव को जानकारी दी गई। लगभग एक घंटे के विविध के दौरान कालीन उत्पादन सहित अन्य तकनीकी पहलुओं से उन्हें अवगत कराया गया। साथ ही आईआईसीटी के आगामी योजनाओं के बारे में भी बातला गया। निदेशक डा. गोस्वामी की मांग पर (आईएसटीएफ) के तहत ट्रेनिंग पाने वाले प्रशिक्षुओं की लगने वाली 27 पीसवट पीस भी भाष्य करने का अनुरोध किया। कहा कि आइआइसीटी कालीन उद्योग के लिए बेहतर प्रयास कर रही है। इसका लाभ उद्योग को उठाना चाहिए। साथ ही प्रशिक्षण



केंद्रीय कपड़ा मंत्री डा. केएस राव के आगमन पर उपस्थित गणमान्य लोग।

कार्यक्रम को और विस्तार देने पर बल देते हुए कहा कि संस्थान के इंचलपमेंट के लिए मंत्रालय से हर संभव सहायता उपलब्ध कराया जाएगा। योजनाओं के लिए प्रस्ताव बनाकर भेजने को कहा।

इस दौरान संस्थान परिसर में पौधरोपण कर पर्यावरण संरक्षण के प्रति बिम्बेदासि का परिचय दिया। उनके साथ मडिहान (मीरजापुर) के विधायक ललितेश पति त्रिपाठी, जिला-उद्योग निर्मात प्रबंधक डा. एडी त्रिपाठी, उर्पाजलाधिकारी बीराम, एसी बरनवाल, तनवीर हुसैन अंसारी सहित कई कार्यवाही नेता व उद्योगी रहे।

आफसरो व उद्योगियों से भरा रहा हाल

भदोही : केंद्रीय कपड़ा मंत्री डा. केएस राव के आगमन पर मंडलायुक्त एसएन शकुना, जिलाधिकारी चंद्रकान्त पांडेय, उमेश कुमार गुप्ता गुप्ता, शोकत अली अंसारी, राजाराम गुप्ता, कमरुद्दीन अंसारी, हाजी जलील अंसारी, शिबसागर तिवारी, हाजी नसरुल्लाह अंसारी, रजा खा, अब्दुल रब अंसारी, अब्दुल सत्तार अंसारी, इरिफाक खा अफ्ट, भरत लाल मीन, सूर्यमणि तिवारी, अरसाद बजीरी, इरिफाक सिद्दीकी, शिबसागर तिवारी, आनंदक अंसारी, एसएन मीन, जेजी गुप्ता सहित

कालीन भेंट कर मंत्री का स्वागत किया

भदोही : केंद्रीय कपड़ा मंत्री डा. केएस राव को सीईपीसी के प्रशासनिक सदस्यों ने बुके व कालीन भेंट कर स्वागत किया। वरिष्ठ प्रशासनिक सदस्य उमेश कुमार गुप्ता, वाशिफ अंसारी, ओकरनाथ मिश्रा बच्चा, भरतलाल मीन, इरिफाक खा अफ्ट, राजाराम गुप्ता ने उद्योग परिदृश्य में प्रथम आगमन पर अभिनंदन किया।

खचाखच भरा रहा एकमा हॉल

भदोही : सीईपीसी द्वारा आयोजित कार्यक्रम के दौरान मंडलायुक्त कालीन भवन पूरी तरह भरा रहा। हाल में परे रखने की वजह नहीं रही। यहाँ तक कि कई कालीन निर्मातक व अधिकारी बाहर ही टहलते रहे। दरअसल कपड़ा मंत्री के आगमन को लेकर उद्योगों का उत्साह था।

दर्जनों निर्मातक मौजूद रहे।

कपड़ा मंत्री के कालीन भवन आगमन पर सीईपीसी के चेयरमैन सिद्धनाथ सिंह व एकमाध्यक्ष ओकरनाथ मिश्रा ने उनका स्वागत किया। इस मौके पर विकास आयुक्त (सीसी हैटिंग) शिबसागर गुप्ता ने प्रशिक्षण केंद्रों को विस्तार देने पर बल दिया। सिद्धनाथ सिंह, विमल कपूर, ललितेश पति त्रिपाठी, अब्दुल हादी ने उद्योग को समर्थना से मंत्री जी को अवगत कराया। संचालन प्रकृमा के मानद सचिव तनवीर हुसैन अंसारी ने किया।

Fig. 32



Shri Alok Kumar, IAS, Development Commissioner (Handicrafts) & Chairman, IICT visiting IICT for attending 52nd SGM and institute day celebration on 1-11-2015.

Fig. 32

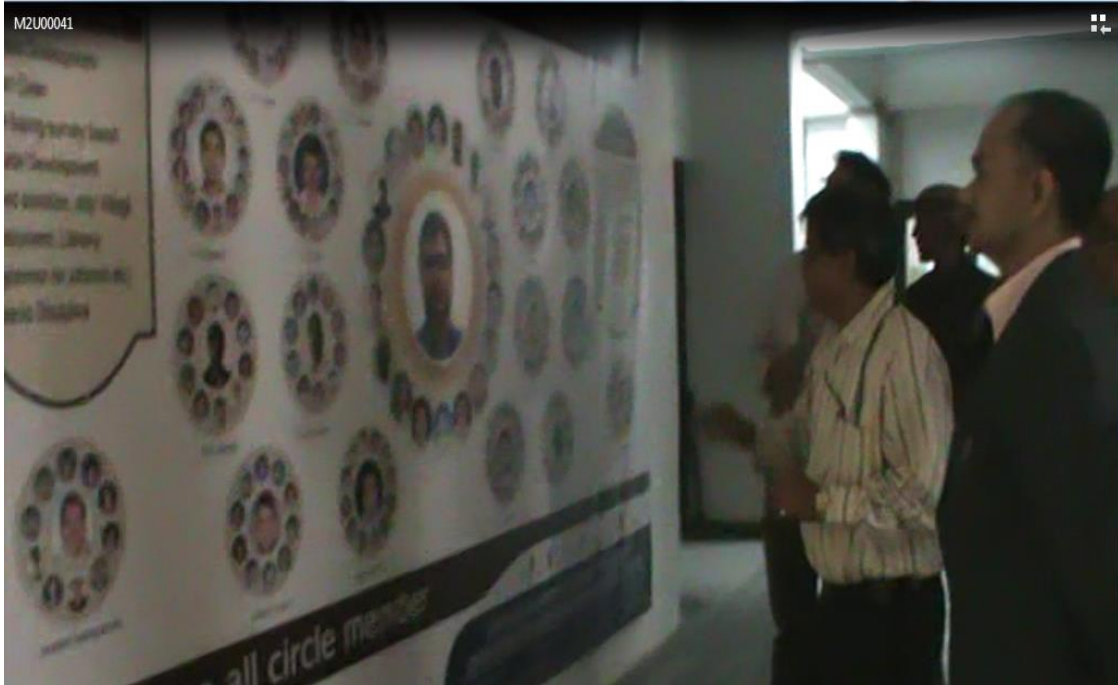

Inspection of Quality Circle at IICT by DC(HC), Chairman, IICT on 1-11-2015

Fig. 33



Inspection of Workshop of IICT by Development Commissioner (HC) & Chairman, IICT on 1-11-2015.

Fig. 34



Development Commissioner (HC) & Chairman, IICT, Divisionla Commissioner, Vindhyachal Mandal & Vice Chairman, IICT & others during 52nd SGM of IICT on 1-11-2015

Fig. 35



Shri J.K.Dadoo, IAS, A.S.& F.A., during meeting with Director, IICT & Director (HC), Vice Chairman, IICT & Staff of IICT.

Fig. 35

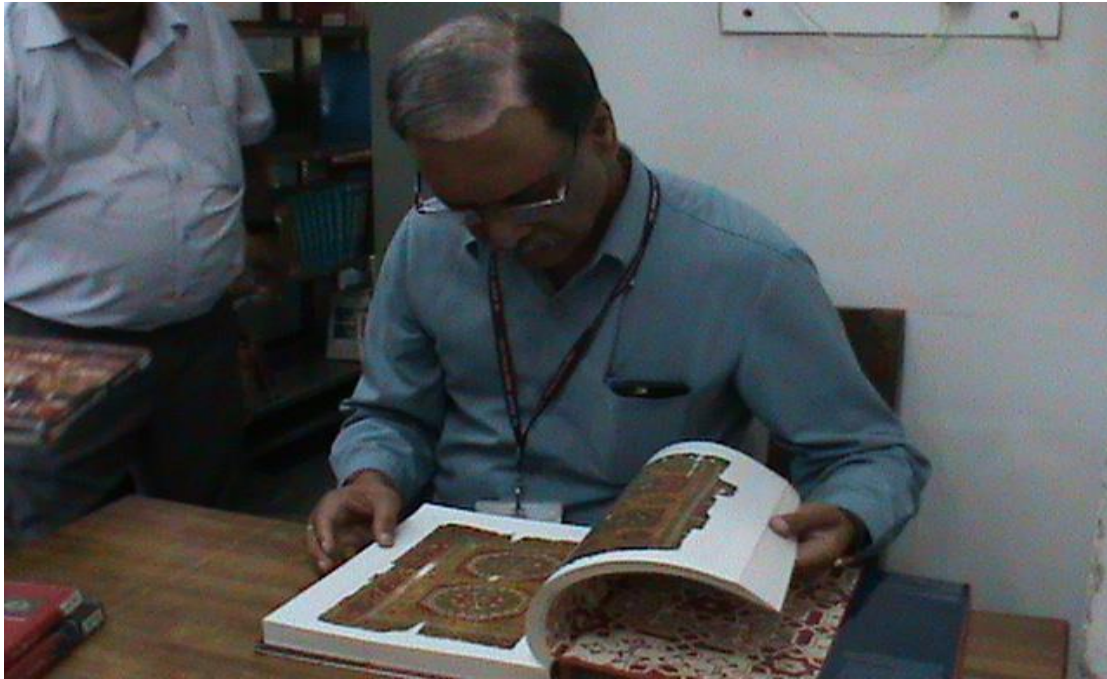

Shri J.K.Dadoo,IAS, A.S.& F.A., during inspection at IICT Library.

Fig. 36



Shri J.K.Dadoo,IAS, A.S.& F.A., during inspection at IICT Workshop.

Fig. 37

 <p>Speakers sharing a common philosophy</p>	 <p>A view of August gathering</p>	
<p>Dr. K.K.Goswami, Director, IICT having discussion during the seminar with Shri Vijay Thakur Ex-Chairman, CEPC, Mr. Farhad Vani, GIZ GMBH, Germany and Ms Astha Garg</p>	<p>August gathering taking view of natural dyes</p>	
 <p>Appreciating presentation of Astha Garg</p>	 <p>Exhibition- High Knottage Recreation of Tehran design in 100% Natural Vegetable Dyes</p>	 <p>Dr. K. K. Goswami With his colleague Dipankar Jana</p>
<p>Ms.Astha Garg addressing to the audience her views about natural dyes</p>	<p>Exhibition – High Knottage Recreation of Tehran Design in 100% Natural Vegetable Dyes</p>	<p>Prof. K.K.Goswami, Director, Indian Institute of Carpet Technology, Bhadohi and his colleague Mr. D.Jana spreading their views about natural dyes</p>
<p>Fig. 39 to 42 Glimpses of Seminar on RENAISSANCE IN NATURAL VEGETABLE DYES jointly organized by India International Centre & Cottage Craft of India on 2nd Sept, 2011 in association with IICT (An effort by Shri Vijay Thakur of CCI & Ex.Chairman, CEPC.</p>		

2. R&D of IICT for the benefit of Industry:
3. 3.1 Use of unexplored vegetable fibers in carpets

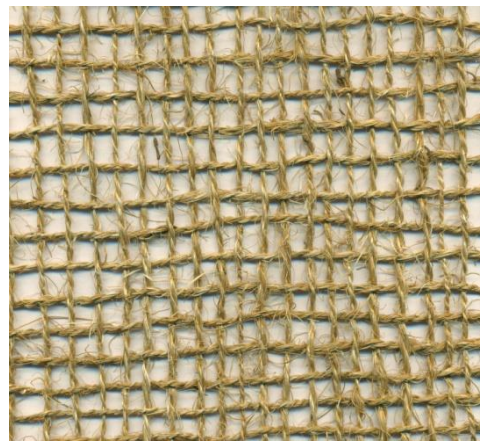
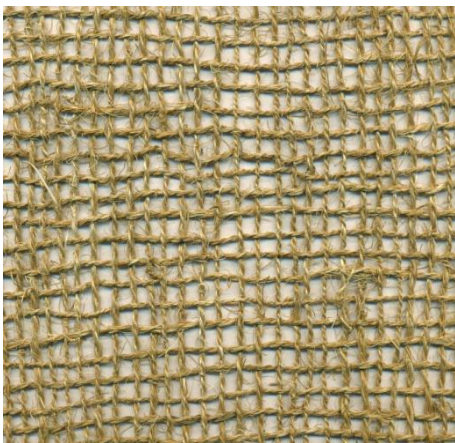

Fig. 43 A view - Application of natural fibers for Home Textiles including floor coverings

SCRIM COIR FABRIC POTENTIAL FOR CARPET BACKING

Fig. 44

2.3.2 Development of artisans-friendly weaving system

Validated and accepted by industry due to reduction of drudgery and comfort to the weavers resulting improved quality and productivity

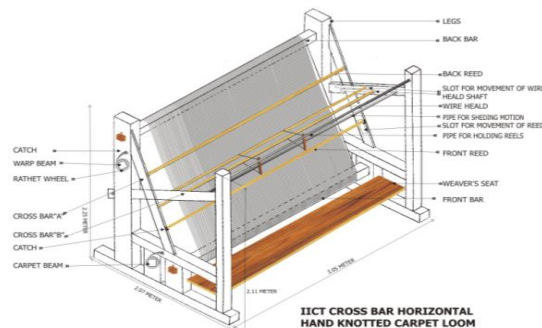

Fig. 45

New Cross Bar Horizontal Loom: Patent obtained and commercialized:

Note: Interested fabricators are invited to contact for taking license for cost effective fabrication.

Development of new technique of Knot formation (India knot)

India Knot:

A new knot Pile Formation Technology in handmade carpet manufacturing. This also has been considered another milestone for the sector and licensing is in process. The technique & logo, both patented. Industry has come forward to take license for India Knot

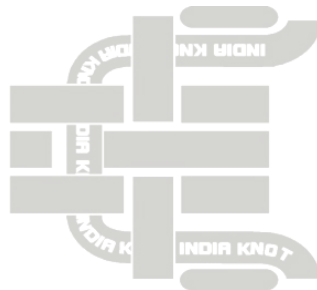

Fig. 46: Depiction of India Knot structure

It is evident that India Knot is very much superior from durability point in different constructional plan. Interested one may contact for taking license for commercial manufacturing and marketing. One can integrate jacquard into the system for enriched designs.

Substitution to latex based backing: Snehabha Carpet Backing

Innovation of carpet backing system (Snehabha Polymeric sheet & Carpet Backing System) which have been patented & registered for the trademark and covered under copyright. Industry has considered this innovation as a milestone for the handmade carpet industry. MSME, Govt. of India has taken step to create a common facility centre involving govt. of UP and M/S Bhawana Ltd as a SPV partner considering this is absolutely new & risky concept but novel with unique setting proposition.



Fig. 47 Prototype Carpet Backing Machine

Salient features:

- Polymeric backing instead of the latex
- Eco-friendly
- Light weight
- Washable
- Cost effective

Software for cost control: CARPCOST Development of CARPCOST: A software for cost management. Software is being covered under Copyright. It has been given to interested industry personnel for their commercial trial and feedback. One can contact IICT for further details. The price of the software is reduced to Rs. 5000.00 significantly from existing Rs. 25,000/- to make the software more accessible by industry. All interested stakeholders are invited to take advantage of this



development.

Fig. 48 Web view of the software

Hand made Astrotuft-1 Billion \$ market for Indian carpet exporters.

Statistical information/background:

Base Data:

Earth surface area = 5,11,821.3 billion m²

World land area = 148940 billion m²

Indian land area = 2973 billion m² (1.99% of world)

Potential & Prospects

Financial market = 250 x 20 bn \$ = 5000 \$bn @20\$/m² of product price.

Present export value of Indian carpets = 0.85 bn\$.

If Indian carpet industry takes share of artificial turf @only 0.02% the market size will be Billion \$ which is more than or equal to the existing market size



Fig. 49

Sample of Artificial Turf vis-à-vis Handmade Artificial Turf- A huge potentiality.



Secretary Textiles, MOT Smt. Rashmi Verma, IAS, at IICT.

Fig 50



Inspection of Campus of IICT by Secretary (MOT) and Development Commissioner (HC) & Chairman, IICT.

Fig 51



Secretary Textiles, MOT and Development Commissioner (HC) & Chairman, IICT, during inspection at IICT Workshop.

Fig 53

Documentation/Publication:

IICT has many publications including books which are mentioned below. The documents may be very useful for the industry. Stakeholders are requested to come forward to utilize the facility available in IICT.

- (i) Dr. K.K.Goswami authored a book entitled “Advances in Carpet Manufacturing” published by M/s Woodhead Publishing House, UK in association with The Textile Institute, Manchester in 2010.
- (ii) A book entitled “Process Control in Manufacturing Home Textiles including carpet” authored by Prof. K.K.Goswami published by M/s Abhishek Publications, Chandigarh.
- (iii) A book entitled “Process Control In Carpet Manufacturing” authored by Dr. K.K.Goswami published by M/s Abhishek Publications, Chandigarh. The Hindi version of this book is also available in market.
- (iv) A book entitled “Performance Measurement of Handmade Carpet Industry” facilitated the research work by Dr K.K.Goswami M/s Abhishek Publications, Chandigarh.
- (v) 2nd edition of book entitled “Advances in Carpet Manufacturing” under process.

SALIENT NATIONAL AND INTERNATIONAL PUBLICATIONS:

More than 70, includes publication in International Journals like AATCC, The Innovation Journal, The Indian Textile, Textile Asia, Melliand Textile Berichte

पुस्तक में इतिहास और आविष्कार साथ-साथ

भयोही। अग्रीका, इंग्लैंड, न्यूजीलैंड, नेल्सियम के लेखकों से सुसज्जित किसी पुस्तक का संपादन अगर किसी अपने ही जिले की किसी विभूति ने किया हो तो निश्चित रूप से यह जिलेवासियों के लिए गर्व की बात होगी। दो टेक्सटाइल इंस्टीच्यूट, मेनचेस्टर के सहयोग से इंग्लैंड की कंपनी द्वारा कालीन पर प्रकाशित पुस्तक का संपादन आईआईटी के निदेशक प्रो.केके गोस्वामी ने किया है। उक्त पुस्तक की पहली प्रति प्रो.गोस्वामी ने जिलाधिकारी को बत्तौर उपहार भेंट की है।

एडवॉंसेज इन कार्पेट मैनुफैक्चर के नाम से प्रकाशित इस पुस्तक का प्रकाशन इंग्लैंड की लुडहेड पब्लिशिंग ने किया है। पुस्तक कालीन को समर्पित है तथा इसमें कालीनों के सैकड़ों वर्षों के इतिहास और इस कला में हुए विवाहस को समेटा गया है। पुस्तक में प्रो.गोस्वामी ने हैडमैड कार्पेट पर प्रस्तावना तथा मैनुफैक्चर और डिजाइन पर दो चैप्टर भी लिखे हैं। गोस्वामी ने पुस्तक की एक प्रति गत दिनों संस्थान में आए डीएम सुरेंद्र सिंह को भेंट की। उन्होंने इसे भयोही के लोगों के लिए गर्व की बात बताया। डा. गोस्वामी ने कहा कि भोरे लिए यह काम किसी अनमोल हीरे से कम नहीं है।

Title	ISBN & Price	Qty	Star
Advances in carpet manufacture	978-1-85573-104-2 £149.00		
Where textiles, design and development	978-1-85573-105-9 £149.00		

Advances in carpet manufacture
Edited by K.K. Goswami, Indian Institute of Carpet Technology, India

- provides an overview of recent developments and innovations in carpet manufacture
- covers the structure and properties of different carpet fibres and yarns
- examines advances in carpet weaving
- discusses a selection of different carpet types including woolens, handmade and sports surfaces
- written by an international team of leading innovators

A BOOK ENTITLED 'ADVANCES IN CARPET MANUFACTURE' EDITED BY DR. K.K.GOSWAMI

Press clips about documentation on MES



PATENTS & TRADE MARKS:

1. A patent vide no 211274("New Polymer Sheet and method of backing carpet or such thick fabric material with the new polymer sheet" awarded
2. Another patent vide no 214269 on the title "A New Carpet Backing Machine to back carpet or such thick fabric material" awarded
3. Two trademarks vide nos 1478866 & 1478867 on " carpet backing obtained.
4. A patent application vide no. 34/Kol//2008 on a method of weaving carpet in Handloom system by a new knot/pile weaving structure' submitted
5. A trade mark vide no. 1634428 on Handloom made carpet as India knot obtained.
6. A patent vide no. 253318 (Cross Bar Horizontal Hand Knotted Carpet Loom having inclined Warp Path) obtained.
7. Method of regenerating cellulose from coir fibre vide application no.149/KOL/2012 submitted.
8. Patent application No.3755/DEL/2015 dated 17-11-2015 "Method of developing sprout/stretch resistant pile integrating terry & leno mechanism for producing value added towel & carpet" submitted.

Views of visitors:

2.6.1 Comments of the Visitors (Abroad) visited institute/ stall during Expo:

Name & Address	Comments
Rahmatullah Garden Khawarizma Aedalusdhu M.N. 9415303933	Total design choosed by me
Nigel Atkinson, Nigel Atkinson Studio, 4 CAMDEN SQUARE, LONDON NW1 9UY. www.nigel-atkinson.co.uk. nigel@nigel-atkinson.co.uk.	Very encouraging to see the creativity and clarity of the work.
Expo - 2012	
Name & Address	Comments
Dr. Parviz Nayyeri experts@setabro.com Iran	Impressive technology and methodology.
Jarvis Rugs Co 73 Jarvis St Toronto Canada Email Jarvisrugs@primus.ca	Excellent
	received CA @ no cost

Date	Name & Address	Comments
22/11/2014		<p>मैं आप का एक प्रश्न केड में आज मैं का कार्य देखना (उत्तर है) मैंने अपने इंटरनेट जाल के पिछले कार्य कार्ड में मैं के निवास के लिए प्रयास किया था उते देखने में बहुत ही जर्न महसूस हो रहा है कि मैंने एक निवास के बारे में बहुत ही उत्तम कार्य का (हकी) आप मैं के कार्य (अधिकारी) से जारी हुई जारी के शीतल नियुक्त हुए हैं निर्णय लिया गया है कि इस निवास का निशान का एक आरबीय रेसिडेंस प्रदाताओं निवास बनाया है। उते कार्य के लिए हमारे प्रयास में आने बरका (मैंने उन्हें मेरी में भी एक प्रयास है। इसलिए मैं निवास इत्यादि कार्य के आरम्भ प्रारंभ दिला। मेरे लिए मैं एक उत्तम प्रतिक्रिया कार्य होगा। इस कार्य में फौजानी एक जोड़ने की भी मेरे साथ मैं में बहुत ही काम प्रारंभ।</p> <p>श्री 3 के साथ मैंने</p>

Date	Name & Address	Comments
05/09/2014	Navendra Shanker Pandey Distt. Magistrate SRN Bhadohi	Visited today on the auspicious day regarding Teacher's day. In the detail conversation, I felt students friendly and director are in teaching spirit. Students are quite intelligent & diligent at the same time. There is good scope for enhancement of the standards of Sush. I wish the best for all good things. [Signature]
09/01/2015	Dr. Martin Kunz Postava GmbH Germany/NK 305864574 (passport)	It is impressive to see the good progress achieved in the year since my last visit. Ad. Thank you for your continued support & signature M.K.
	MARCIANNE LANDRETTTEL PROLANA GmbH 305863230 (passport)	Thank you for your kind and explanation. It has been a most helpful, interesting and educational afternoon. M. Landrettel

Date	Name & Address	Comments
10/1/15	JK Dadas IAS Add Secy & Financial Advisor Min. of Commerce & Textiles	A pioneer institute in Compet. technology. Has needs application facilities in classrooms, testing labs, teaching infrastructure. Sush. Khoreat is a minority. Green, solar water harvesting, solar energy generation, compost pits, water harvesting. Have fruit trees & flowering plants, etc. reqd. More customers at in K.D. projects, full-time training & self-help groups, and maintenance of Khushi record is important. He should not shine in excellence become an institute of National members by best wishes JK Dadas 10/1/15

Message of Prof. Kripa Shanker, Vice-Chancellor, Gautam Buddha Technical University, Lucknow.



गौतम बुद्ध प्राविधिक विश्वविद्यालय
(पूर्ववर्ती उत्तर प्रदेश प्राविधिक विश्वविद्यालय)
Gautam Buddha Technical University
(Formerly Uttar Pradesh Technical University)



आई.ई.टी. परिसर, सीतापुर रोड,
लखनऊ-226 021 (उ० प्र०) भारत
I. E.T. Campus, Sitapur Road,
Lucknow-226 021 (U.P.) India

प्रो० कृपा शंकर
कुलपति
Prof. Kripa Shanker Ph.D. (Cornell)
Vice Chancellor

Dated :28.10.2010

MESSAGE

I am delighted to know that Indian Institute of Carpet Technology, Bhadohi is publishing the student's magazine "Tana-Bana".

The regular Co-curricular activities like brainstorming sessions, seminars, workshops, publication of student's magazine and other literary activities are ideal medium for the student to manifest creativity and give expression to their thought process. I hope that the publication of the magazine will go a long way in educating students in the field of creative writing and expression, subsequently leading for their overall personality development.

I convey my best wishes for the successful publication of the Magazine.

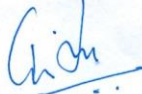

(Prof. Kripa Shanker)
Vice Chancellor

Message of Dr. R.K.Khandal, Vice-Chancellor, Gautam Budhha Technical University, Lucknow (formerly Uttar Pradesh Technical University).

Dr. R.K. Khandal
Vice Chancellor



GAUTAM BUDDH TECHNICAL UNIVERSITY
(Formerly Uttar Pradesh Technical University)
I.E.T. Campus, Sitapur Road, Lucknow-226 021 (U.P.)

Dated : 01.11.2012

Sub.: Celebrations of 12th Institute Day on 1st Nov. 2012 by IICT; Our Message

Dear Prof. Goswami,

It is a matter of great pleasure to note that the faculty and students of IICT would be celebrating their Institute day, today. It would have been my honour to be personally present amongst you on this occasion but I am sorry to say that I would not be able to make it in spite of my keen desire to do so. Due to certain unforeseen reasons, I have to beg your pardon at the last moment.

In order to register our appreciation for your efforts, I would like to express that:

- (i) The social activities, such as 'Blood Donation', 'Creating awareness of Care & Fare School Children from carpet weavers' families etc. by students of IICT, are commendable.
- (ii) Director IICT and his whole team deserve kudos for the praise-worthy record of academic performance of the students. University acknowledges it as a remarkable achievement of IICT.
- (iii) The demand of change of name from "Indian Institute of Carpet Technology (IICT)" to Indian Institute of Carpet and Textile Technology (IICTT) seems relevant and worth considering.
- (iv) The plans of IICT to start new courses i.g. 'B.Tech in Fashion and Apparel Technology' and 'M.Tech in Textile Management' are appreciated. G.B. Technical University will provide all possible support necessary to affiliate these courses, in public interest.
- (v) Considering the research and academic potential, G.B.T.U. would encourage IICT for Pre-Ph.D mentoring/examination centre to promote scholastic activity.
- (vi) G.B. Technical University will extend all possible support for students and faculty.

With the above statements, I wish IICT -'An Institute with difference' functioning under the dynamic leadership and administrative control of Development Commissioner (Handicrafts) Ministry of Textiles, Govt. of India, a huge success in all its endeavours. Under the stewardship of Prof. Goswami, I have no doubt that IICT will certainly become a true international academic/research/referral centre in textiles.

I wish 12th Institute day a success and many happy returns of the day.

R.K.Khandal
11/11/2012
(Dr. R.K. Khandal)
Vice Chancellor

Prof. (Dr.) K.K. Goswami
Director
Indian Institute of Carpet Technology (IICT)
Chauri Road, Bhadohi-221401

Phones : (Off.): +91-522-2732194, (Fax): +91-522-2732189, (Res.): +91-522-2731631
Email : rkhandal@upty.ac.in, vc@upty.ac.in Website: www.upty.ac.in

Comprehensive Achievements note:

Design Creation & Development (DCD)

Institute has got full fledged state of the art Design Studio & CAD Centre to take up Design Creation & Development Work to serve Wool, Carpet & Textile Industry.

Design / Naqsha creation for the Industry

Utilization of CAD facilities for Research & Services over design for industry

Training: Potential designers are being trained who are either self employed or employed

Design Bank: State of the art reference/ search engine suitable for various carpet constructions

डिजाइन सेवाओं का वितरण

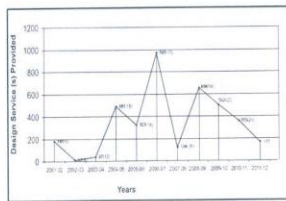

Technical Service to Industry (TSI):

Institute can serve the related industry covering wool, carpet & textiles

Sample Testing & Certification: Laboratory (Carpet & Textile : Physical & Chemical) serves the industry over the years.
Laboratory Accreditation (NABL) : Mechanical & Chemical Consultancy: Technical & Management consultancy to Industry directly and through sponsored projects covering Troubleshooting also.

Workshop: Facilities created is capable of research & development of various samples :: Yarn : Cotton, Woollen, Dref, Openend, Carpets : Handmade, Loom & Machine made. Fabrics: Woven, Jacquard, Terry & Chemical Processing: Dyeing of fibre to fabric, finishing of fabric & Carpet includes Innovative Backing of Carpets & Such thick Fabric materials.

परीक्षण सेवाएं उद्योग को तकनीकी सहयोग (टी.एस.आई.)

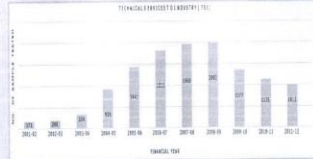

06 Consultancies/ Technical Services Provided.

For details on time frame & charges for the services refer "Tariff Schedule" and visit website: <http://iict.ac.in>
Kindly Contact Director IICT for further clarification & Assistance



ISO 9001:2008 Certified by SGS U.K.



INDIAN INSTITUTE OF CARPET TECHNOLOGY

(Under the aegis of the Development Commissioner (Handicrafts), Ministry of Textiles, Govt. of India)
Affiliated with U. P. Technical University & Approved by AICTE, Ministry of HRD, Govt. of India
Chauri Road, Shadab, 201401 Tel: 15414 22554, Fax: 15414 22559
Email: info@iict.ac.in Web: <http://iict.ac.in>



IICT is promoted by Ministry of Textiles, Govt. of India under the aegis of Development Commissioner (Handicrafts). It has become academically functional in 2001 through commencement of first ever Degree Course i.e. B. Tech in Carpet & Textile Technology unique of its kind.

- IICT is approved by All India Council for Technical Education (AICTE) and affiliated to U.P. Technical University (UPTU).
- IICT is approved by Central Counselling Board & All India Engineering Entrance Examination of Ministry of HRD Govt of India Technical for admitting B. Tech Aspirants
- IICT is accredited by the Textile Institute, Manchester, UK.
- IICT is awarded coveted ISO 9001:2000 in the year 2005 by SGS, UK.
- Accreditation by National Accreditation Board for Laboratory (NABL) for Mechanical & Chemical Laboratories of IICT.
- IICT operates on undermentioned four portfolios.

PORTFOLIOS WISE ACTIVITIES / ACHIEVEMENT

Human Resource Development (HRD)

A B Tech in Carpet & Textile Technology:

The course is at present limited to Indian Nationals. Possibility of admitting NRI/PIO/ foreign students is being explored with the concerned authorities. Curriculum details are available on the Institute's website.

Internship available with Industry: Local, Carpet, Wool, Textile and All India basis

Placement : Through Placement Cell /Professional/Campus Interview

Additional Disciplines like Advances in Carpet Technology (ACT) Home Textile Technology (HTT) & Textile Designing Technology (TDT) have been integrated as specialization in the final year.

Graduated : 209/ Placed : 80 to 85% Under Graduation : 165

B International Distance Learning Programme (IDL/P):

7 diplomas and 30 certificate course on wool, carpet & textiles are offered under the programme. Possibility of admitting NRI/PIO/ foreign students is being explored with the concerned authorities. Curriculum details are available on the Institute's website.

1. Diploma in Basic Textile Technology (Six Certificates Topics)
2. Diploma in Wool Scouring Technology (Six Certificates Topics)
3. Diploma in Textile Dyeing and Finishing (Six Certificates Topics)
4. Diploma in Carpet Yarn Manufacture (Six Certificates Topics)
5. Diploma in Carpet Technology (Six Certificates Topics)
6. Diploma in Apparel Yarn Manufacture (Six Certificates Topics)
7. Diploma in Carpet & Textile Designing (Six Certificates Topics)

Recognised by :-

Distance Education Council-AICTE-UGC joint committee, Govt. of India

Enrolled Candidate: 5 Study Centers: 3

C Industry Driven Training Programmes:

Skill upgradation programme under Integrated Skill Development Programme (ISDS) of Ministry of Textiles, Govt. of India.

Skill upgradation Programme under Comprehensive Handicrafts (Carpet) Cluster Development scheme (CHCCDS) Govt. of India.

Short Term Training programmes on Modular Employable Skills covering various approved / Need based on Modules related to Carpet & Textiles

Skill development cum orientation programme for Artisans: Weavers, Dyers, Instructors, Supervisors etc.

Workshop on Technical & Design Development. Institute can offer tailor made (Need based) training programme on:

Wool Technology: Raw material to finishing including marketing
Carpet Technology: Introduction in Carpet Manufacturing to Advance Carpet Manufacturing.

- o Textile Technology: Fibre to Fabric
- o Special programme on usage of Natural Fibres & Natural Dyeing.

More than 2500 artisans have been created

More than 7000 artisans are being trained in coming 3 years

Research & Development (R&D):

Institute undertakes sponsored R&D Project on any theme related to wool, carpet & textile on mutual acceptable understandings.

Technology Up gradation:

- i) Looms, tools & equipments .
- ii) New Carpet Backing System: Substitute to existing hazardous system has been developed and Patented.
- iii) New Cross Bar Horizontal Loom: Validated and accepted by industry due to reduction of drudgery and comfort to the weavers resulting improved quality and productivity. The design is patented.
- iv) Innovation of carpet backing system (Snehabha Carpet Backing System) which has been patented & registered for the trademark and covered under copyright. Industry has considered this innovation as a milestone for the handmade carpet industry and being commercialized.
- v) Concept of India Knot a new knot / Pile Formation Technology in handmade carpet manufacturing. This also has been considered another milestone for the sector and licensed. The technique & logo, both being patented.

Product Development:

Intervention of New materials like Natural Vegetable fibres, Eri Silk, Mod Acrylic, Art Silk and Modern Yarn, Introduction of Natural dyes.

Standardization:

Carpcost software developed by IICT under copyright meant for standardization for Cost & Quality through monitoring inputs & process



2.3 If the project pertains to category 2.1 (c), please indicate steps initiated for obtaining approval of Full Planning Commission:

Not Applicable

3. Justification for the project:

3.1 The justification for taking up/continuing the project or scheme may be provided:

The need has been felt by University, Industry and management to make the institute viable and long-lasting as evident from documents annexed. The addition of M. Tech. in Carpet & Textile Management (CTM) to the existing field will increase the scope of service. The export turnover of the sectors together is not less than Rs. 25000 crores (3500 crores for Carpet, 4000 for Home Textiles & 17500 for rest). There is no such institute which can serve the need of the sectors in portfolios like HRD, DCD, R&D and TSI. Therefore, need for expansion of IICT is absolutely justified and could be the right decision on the part of Govt. of India.

Proposed Strategy:

The proposed strategy for implementation of different issues, which mentioned above includes initiation of

- Addition of relevant discipline M.Tech in Carpet & Textile Management (CTM)
- Extension of R&D to cover the need of the academic and industry.
- To act over Strength, Weakness, Opportunity & Threats (SWOT)
- To serve more sectors like Fashion and Apparel besides wool, home textiles including Handmade and Machine made Carpet & designing.

Therefore, their course content, curriculum, fee structure, student selection mechanism etc. for the relevant disciplines and strategy /proposal for other activities need to be in place as has been included as under:

Strategy-wise action plan:

No.	Action	Remarks
1.	Addition of relevant discipline like M.Tech in Textile Management	To take up with University, AICTE and AIMA for initiation of affiliation and approval so that this course can be started w.e.f. 2017-18 academic year after expiry of the current phase-II of the project.
2.	Extension of R&D to cover the need of the academic and industry	To provide the service of Institute through academic and industrial R&D in need based manner. The other sector like Fashion and apparel industry also would be added as our stakeholders. To take up with the stakeholders to finalize the tentative indentified agenda. IICT will strengthen its R&D base in terms of enrollment for research scholars in all areas of textiles and management. Moreover, it will make its attempt to become a study centre for pre Ph.D works of the university.
3.	To act over Strength, Weakness, Opportunity & Threats (SWOT)	A cell will be created to generate data base through research and development in terms of market intelligence so that industry can become more pro-active in their decision related to trade.
4.	Incorporation of natural fibres like Jute linen, wool & silk aspects in the course curriculum and additional disciplines being installed	In the new syllabus necessary additions in subjects like: Fibre Science, Yarn Manufacturing, Advance Fabric Manufacturing, Internship, Project wherever scope existed so that future trainees/graduates /scholars more effective for the promotion of natural fibres.
5.	Synergy	IICT recognizes organizations like All India Carpet Manufacturing Association(AICMA), Carpet Export Promotion Council (CEPC) , other textile and related export promotions council including AEPC, Indian Woolen Mills Federation (IWMF) , Export Promotion Council for

No.	Action	Remarks
		Handicrafts (EPCH) and Wool & Woolen Export Promotion Council (WWEPC) ,Central Wool Development Board(CWDB), Ag-research (Newzealand), The Textile Institute Manchester and other potential institutes / organizations as valuable partners of IICT for having synergy in mutual interest of utilization of resources created and being created around all portfolios (HRD,R&D, DCD, TSI).
6.	Road map beyond 2016-17	The new SFC is proposed for next 5 years w.e.f. 2016-2017. Therefore the road map has been restricted to till 2020-2021 only. The year 2020-2021 shall be the 19 th functional year considering 2001-2002 as the 1 st functional year, As per target given by EFC dated 5.10.1998 the 1 st functional year should have been 2001-2002. Year wise and activity wise self sustainability plan for IICT,Bhadohi projected in the last EFC vide annexure-V of the documents provides target of 100% generation of revenue over recurring expenditure excluding pay and allowance (copy enclosed). IICT is committed to maintain the similar self sustainability plan till 2021-29.

Strategy & programme for extension of knowledge and skills benefiting the local people pursuing carpet trade:

Strategy No.	Area	Strategies/ Remarks
1	Extension of knowledge & skill benefiting local people in particular but all concerned in general	<ul style="list-style-type: none"> • IICT shall become a platform wherein all concerned who has enriched knowledge through Govt. assistance shall share with all relevant beneficiaries of the trade. • Net surfing guidance and facility on charge basis • Veteran personality from country and abroad shall be called to conduct programmes on issue of interest to carpet & textile trade time to time.
2	SWOT Analysis benefiting all concerned	Analysis & interpretation of data by IICT by means of collection of SWOT data through: <ol style="list-style-type: none"> 1. Visiting various websites. 2. Contacting various embassies 3. Contacting various councils of the world 4. Visiting various countries.
3	Incorporation of additional disciplines to make the Institute viable (continuation of 100% revenue over recurring expenditure other than pay and allowance and may all attempt to become self sustainable w.r.t. total recurring expenditure from year 2019-20 onwards)	To start M.Tech in Carpet & Textile Management (CTM) in addition to various modular courses which is likely to expend activities in the country in general and Bhadohi in particular. The module(s) to be integrated in course curriculum are: Fashion, Information Technology, Accounting, Business Management etc. as visualized by Secretary (Textile)
4	Mobile Service	In today's context, door-to-door service is well accepted/ appreciated, which has been the advice of His Excellency A. P. J. Abdul Kalam

		<p>President of India on the eve of Golden Jubilee resurgence of Handicrafts held at Vigyan Bhawan, dated 15.11.2002. Hon'ble President appreciated the role of IICT to serve such a rural sector and further advised Director IICT to become mobile. To implement above said strategy, procurement of required vehicles and mobile equipments is the pre-requisite.</p>
--	--	--



His Excellency, President of India in discussion with Director, IICT during his visit to IICT gallery on the eve of Golden Jubilee of Handicrafts Resurgence in India on 15.11.2002 at Vigyan Bhavan, New Delhi in presence of other dignitaries.

3.2 The alternative that have been considered before firming up the design of the project may be stated. (this should also include alternate modes of project delivery, e.g. outsourcing PPP etc. that have been considered):

Not Applicable

3.3 Please state whether the project proposal has objectives and coverage which overlap with project / scheme being implemented by the same or another agency (Ministry/Department/ State government). In case of overlap, please

state why the project scheme need to be considered as a separate stand alone effort:

There are no other scheme with overlapping objectives and coverage.

4. Project Objectives and Targets:

4.1 The objective of the project may be mentioned. These objectives should flow from the project justification:

The IICT after getting started in November 2001 could grow as desired to make it a Center-of-Excellence and endeavors made it to reach International Standard. However, achieving further excellence is in process.

The main objective of the scheme will be as under:

- Optimum utilization of resource
- Addition of relevant discipline M. Tech in Carpet & Textile Management (CTM)
- Extension of R&D to cover the need of the academic and industry.
- To act over Strength, Weakness, Opportunity & Threats (SWOT)
- To serve more sectors like Fashion and Apparel besides wool, home textiles including Handmade and Machine made Carpet & designing.

4.2 The Expected date of project/ scheme completion may be stated. This should be realistic and supported with a chart indicating timeline for the important activities, with a critical path analysis, identifying the main constraints.

5. Project Design:

5.1 Briefly explain the project Design. This should include all components of the project:

- Continuation of earlier project & introduction of M.Tech. in Carpet & Textile Management (CTM).
- Improvement / upgradation of existing infrastructure.
- Addition of infrastructure .
- Continued support of Pay & Allowances under Non-plan.

5.2 In case the project or scheme is location specific, please state the basis for selection of such location:

Expansion in the same location since no additional land is required. Additional land 20 acre provided to IICT can be better utilized.

- 5.3 If the project involves creation/modification structural and engineering assets or change in land use plans, disaster management concerns as brought out in O.M.No.37 (4)PF-II/2003 dated 19-6-2009 should be assessed. A self certification in this regard in the EFC Memo:**

Not applicable

- 5.4 In the case of beneficiary oriented project/ scheme, the mechanism for identification of the linkage of beneficiary identification with UID numbers may be indicated as advised in O.M. No. 1(3)/ PF- II/ 2001 dated 09.08.2010.**

Not applicable

- 5.5 Wherever possible, the mode of delivery should involve the panchayati Raj Institutions and Urban Local Bodies. Where this is intended, the preparedness and the ability of the panchayats for executing the project may be indicated. If exceptions are to be made, the reasons may be explained.**

Not applicable

- 5.6 In case the project involves land acquisition or environmental clearances, the specific requirements and the status in this regard may be indicated.**

Additional land ~20 Acre already provided by U.P. Government.

- 5.7 The legacy arrangements after the scheduled project duration may be mentioned. In case the project creates assets, arrangements for their maintenance and upkeep may be stated. (For example the project assets may be taken over and maintained by the State Government/ PRIs; ULBs).**

IICT is a Governmental Society. the Executive Committee with government direction to take all necessary steps.

- 5.8 Whether the guidelines of Bureau of Energy Efficiency and other related guidelines for energy efficient buildings etc. have been considered/ complied with.**

The constructional Consultant i.e. M/s Awas Evam Vikas Parisad, Varanasi is a approved U.P. Government Construction Agency. The TOR shall stipulate such condition that the guidelines of Bureau of energy Efficiency and other related guideline for energy efficient building etc. become mandatory.

- 5.9 Whether the project is secured against natural/ man-made disasters like floods, cyclones, earthquakes, tsunamis etc.**

All necessary steps will remain in built wherever applicable including appropriate insurance coverage.

6. Project/ Scheme cost

6.1 Please provide the project cost estimate for its scheduled duration along with a breakup of year-wise, component-wise expenses segregated into non-recurring and recurring expenses. It may also be indicated whether land is needed, if so whether which agency is providing for it, and in case the cost of land is to be booked to the project, whether it has been included in the estimates:

Summary of Expenditure in Rs. lakhs from 2016-17 to 2020-21

Summary of activity	Non Recurring	Recurring	total	Remarks
Continuation of existing B.Tech (CTT with specialization), M.Tech. in Carpet & Textile Management (CTM) and other portfolios	5423.36	1417.87	6841.23	<ul style="list-style-type: none">• Details of Non-recurring expenditure as per Annexure-III• Details of Recurring expenditure as per Annexure-VI

Annexure-III

A-Proposed Non-recurring Expenditure plan under EFC (Existing activity for the year 2016-17 to 2020-21)

S. NO.	Particulars of Items	Estimated Cost Rs. in Lakhs
<u>Non-Recurring Expenditure at Pipris</u>		
1.1.	<u>Construction & Development Works in IICT Campus at Pipris, Bhadohi Area~ 20 Acres.</u>	
1.1.1.	Area Development works including leveling , Internal Roads, Paths, Sewer, Water supply lines, Storms water drains, horticulture etc. @ Rs.600 per m ² for ~45,000 m ² out of total area.	270.00
1.1.2.	Completion/ re-enforcement, fencing work of boundary wall~1500 m@ Rs.12,000/- per running meter.	180.00
1.1.3.	Hostel Building for 120 inmates with Provision of 60 rooms , total 2200 m ² area @ Rs. 18,000/- per m ² & Furniture for 60 rooms @Rs. 25,000/- per room. With international level facilities also.	411.00
1.1.4.	Workshop/Lecturer Theater	
	• Workshop @ Rs. 11,250/- per m ² for 2400 m ² with provision of Store	270.00
	• Lecturer Theater Building @ Rs. 18,000/-per m ² for area 1375 m ²	247.50
	• Furniture & fixtures for Lecturer Theater Building @ Rs. 2,181/- per m ² for 1375 m ²	30.00
1.1.5.	Administrative Building	
	• Building @ Rs. 18,000/- per m ² for area 2400 m ²	432.00
	• Furniture & Fixture @ Rs. 2,500/- per m ² for 2400 m ²	60.00
1.1.6.	Staff Accommodation building @ 18,000/- per m ² for 2500 m ²	450.00
1.1.7.	O.H.T., Pump room, Generators etc.	100.00
1.1.8.	Guest House/Faculty House/Alumni block	
	• Building Rs. 18,000/- per m ² for 1200 m ²	216.00
	• Furnishing @ 2500/- per m ² for 1200 m ²	30.00
1.1.9.	Play ground & amenities for students –developing ~1200 m ² area with amities @Rs.10,000/- per m ² (Part activity may be undertaken in Chauri Road Campus)	120.00
Sub Total (A)		2816.50
1.2.	<u>Construction & Development works in IICT Campus at Chauri Road, Bhadohi</u>	
1.2.1.	Vertical Extension by one floor in Existing Director's Bungalow 269.28 m ² & Staff Quarter (Existing 2 floor buildings 2 Nos., 139.77 m ² and 219.54 m ²) Total area 628.59 m ² @ Rs. 18,000/- per m ²	113.15
1.2.2.	Vertical Extension by one floor in Existing Academic block to accommodate library & Class Room (s)	
	• Building 1200 m ² @ Rs. 18000.00 per m ² .	216.00
	• Furniture & Fixture@ Rs. 2500 per m ² for 1200 m ²	30.00
1.2.3.	Modification of Conference Hall –area 464.15 m ²	
	• Including furniture & fixtures @ Rs.12500/- m ²	58.02
	• Auditorium on existing Conference Hall–area 464.15 m ² @Rs.25,000/- per m ²	116.04

	1.2.4.	Extension of Open Air Theater area ~450 m ² @Rs. 8,500/- per m ²	38.25
		Sub Total (B)	571.46
		Total (A+B)	3387.96
1.3.	Electrical Works @ 8% of above(A+B) -C		271.04
		Sub Total (A+B+C)	3659.00
1.4.	Consultancy fee@ 12.5 % of Sub Total (A+B+C) - D		457.38
		Sub Total (A+B+C+D)	4116.38
1.5.	Contingencies		55.82
		Total (A+B+C+D+E)	4172.20
Variation in quantities within estimated cost may be considered			
2.1	Additional Works to be undertaken as per direction of Higher authorities & emerging needs		
	2.1.1.	Enhancement in Teaching Infrastructure/classroom activities - Overhead projectors in 4 classrooms (~ Rs.85,000/- X 4 Nos.), Electronics Display boards (~Rs. 75,000/-X 4) etc.	10.00
	2.1.2.	Swachh Bharat Mission –heavy duty machine/equipments of sweeping -2 no.@ Rs.3.5 lacs, Miscellaneous sweeping items like hand trolley, litter bins etc.	10.00
^^^	2.1.3.	Greening -Development of Green Belt	5.00
	2.1.4.	Rain water harvesting covering area of terrace in buildings and open floor area	50.00
	2.1.5.	Solar Energy generation ~ 125 KW	296.00
	2.1.6.	Compost pits – 2units	2.46
	2.1.7.	Effluent Water Treatment Plant	10.00
	2.1.8.	Community centre (Dispensary/Yoga/Recreation etc.)	15.00
	2.1.9.	Independent vehicle for Director, IICT	12.00
	2.1.10	Ambulance for students	8.00
	2.1.11	Books for Library	30.00
		Sub Total (F)	448.46
3.1	Plant & Equipments (details as per annexure- VI)		802.70
		Grand Total	5423.36

Note: Provision exist for construction of proper ramp(s), to take care of movement of handicapped person in the building(s).

B-Proposed Recurring Expenditure Plan under EFC (Existing activity for year 2016-17 to 2020-21) Rs. in lakh Annexure-VI

	B-Recurring Expenditure	Total	2016-17	2017-18	2018-19	2019-20	2020-21
R-1	Pay & Allowances						
	vances for additional 26 posts.	747.87	100.50	120.60	144.72	173.66	208.39
OR	Other than Pay & Allowances						
R-2	TA/DA (including foreign travel)	55.00	9.00	10.00	11.00	12.00	13.00
R-3	Electricity Expenses						
R-4	1) Electricity from UPPCL	30.00	4.00	5.00	6.00	7.00	8.00
	2) Diesel for Generator	85.00	14.00	16.00	18.00	18.00	19.00
R-5	Raw Materials & Cosumables for Lab	25.00	3.00	4.00	5.00	6.00	7.00
R-6	Repair & Maintenance	50.00	8.00	9.00	10.00	11.00	12.00
R-7	Petrol & Diesel for Vehicle etc.	7.50	1.50	1.50	1.50	1.50	1.50
R-8	Printing & Stationary	30.00	4.00	5.00	6.00	7.00	8.00
R-9	Advertisement	25.00	3.00	4.00	5.00	6.00	7.00
R-10	Workshop & Seminars	7.50	1.50	1.50	1.50	1.50	1.50
R-11	Staff Training & Exhibition etc.	10.00	2.00	2.00	2.00	2.00	2.00
R-12	Membership Fees	10.00	2.00	2.00	2.00	2.00	2.00
R-13	IICT-Industry interface for (involving faculty as mentor & students as resource) a technical process, product development support including E.D.P.	71.00	10.00	12.00	14.00	16.00	19.00
R-14	Internationalization (Admission & interface: visits/collaboration)	95.00	15.00	17.00	19.00	21.00	23.00
R-15	Market intelligence cell	54.00	8.00	10.00	11.00	12.00	13.00
R-16	Journals (National & International)	20.00	4.00	4.00	4.00	4.00	4.00
R-17	Professional Fee	5.00	1.00	1.00	1.00	1.00	1.00
R-18	Auditors Fees	5.00	1.00	1.00	1.00	1.00	1.00
R-19	AMC for Plant & Equipments, Outreach Activity & Other Contingency (unforeseen expenditure)	85.00	17.00	17.00	17.00	17.00	17.00
	Sub total other than Pay & Allowances	670.00	108.00	122.00	135.00	146.00	159.00
	Grand Total	1417.87	208.50	242.60	279.72	319.66	367.39

Note: Pay & Allowances for regular sanctioned post is covered under Non Plan and provision for additional 26 posts approved by EFC Rs.747.87Lakhs is proposed to be added under Non Plan.

BREAK UP OF TARGET REVENUE (HRD, DCD, R&D, TSI AND ADDITIONAL) CUM SELF SUSTAINABILITY PLAN
Annexure-V

	Portfolios/ Year :New phase (functional)	All figures are in Rs. (lakhs)					
		Total	2016-17	2017-18	2018-19	2019-20	2020-21
1	HRD						
	* B. Tech.	550.00	110.00	110.00	110.00	110.00	110.00
	*M.Tech.	87.60	00.00	10.50	17.90	25.90	33.30
	* Other Programmes	75.00	15.00	15.00	15.00	15.00	15.00
		712.60	125.00	135.50	142.90	150.90	158.30
2	DCD						
	* Creation, CAD Rental, Color Xerox/ Other, * Sampling etc	28.00	04.00	5.00	6.00	6.00	7.00
		28.00	04.00	5.00	6.00	6.00	7.00
3	R&D						
	* Product	40.00	5.00	6.00	8.00	10.00	11.00
	* Project consultancy/ overhead @20%	38.00	5.00	7.00	8.00	9.00	9.00
	* Technology Transfer etc.	38.00	5.00	7.00	8.00	9.00	9.00
		116.00	15.00	20.00	24.00	28.00	29.00
4	TSI						
	* Sample Testing	25	3.00	4.00	5.00	6.00	7.00
	* Certification of Products	10	2.00	2.00	2.00	2.00	2.00
	* Others (Home Textile Lab, Advance Carpet Lab, Spinning Lab, Weaving Lab, Engg. Lab)	18	2.00	2.50	4.00	4.50	5.00
		53.00	7.00	8.50	11.00	12.50	14.00
5	Additional	9.5	1.50	2.00	2.00	2.00	2.00
	GRAND TOTAL (1 to 5)	919.10	152.5	171.00	185.90	199.40	210.30
	Recurring expenditure	670.00	108.00	122.00	135.00	146.00	159.00

SELF SUSTAINABILITY PLAN:

	Total	2016-17	2017-18	2018-19	2019-20	2020-21
Revenue Generation	919.10	152.5	171.00	185.90	199.40	210.30
RE (excluding pay & Allowances (REC))	670.00	108.00	122.00	135.00	146.00	159.00
% Rev/Rec	137.18	141.20	140.16	137.70	136.58	132.26

Students Enrollment Statistics:

Year	Undergraduate & Post Graduate				Total
	B.Tech. (Existing CTT)	M.Tech. (CTM)	Ph.D	IDLP	
2016-17	276	--	5	50	331
2017-18	276	20	10	100	406
2018-19	276	40	10	100	426
2019-20	276	40	15	100	431
2020-21	276	40	20	100	436
Total	1380	140	60	450	2030

List of Equipments:

Sl. No.	Name of the Lab	Name of the Equipments*	Number of Unit	Estimated Price (Rs)	Justification
1	Advance Carpet and Textile design Lab	1) Dobby design software 2) Jacquard design software 3) Design Computer System(25) 4) HP Colour plotter 24" (1) 5) HP Colour plotter 36" (1) 6) Nedgraphics software new(5) 7) Chromo tone shades 2013 (1) 8) Small size computer table(25) 9) Projector with stand screen (1) 10) Round chair (25) 11) LCD monitor 48" (1) 12) Split AC (1) 13) ARS colour shade wool (1600) (1) 14) ARS silk colour shade (1) 15) Almirah (3) 16) Printer (1) 17) Color printer (1) 18) HP Scanner (5) 19) Designer digitizer pen (10) 20) Studio designer table (2) 21) Chair (2) 22) Tracing table (2) 23) 5KVA UPS (2) 24) Pin board (5) 25) Classroom board (1) 26) Camera (1) 27) Internet broadband (1) 28) Manual design dev. Lab 29) Computer accessories 30) Manual design dev. Table (25) 31) Chair (50)	1 1 25 1 1 5 1 25 1 25 1 1 1 1 1 1 3 1 1 1 1 10 2 2 2 2 2 2 2 5 1 1 1 1 -- 25 50	80.00	To meet the academic and industrial requirement
2	Advance Carpet & Fabric Manufacturing Lab	1) Beam warping machine 2) Sizing machine 3) Sectional warping machine 4) Shuttle less loom with electronic doobby 5) Electronic jacquard fitted needle loom 6) Rug weaving machine		80.00	To meet the academic and industrial requirement
3	Home Textile Lab	1) Single needle lock stich (25) 2) Progamable lock stich (2) 3) Sewing machine with different feed M/c (5) 4) Chain stich (2) 5) Over lock (2) 6) Interloc (2) 7) Button Hole (1) 8) Button Attach (1) 9) Bartack (2) 10) Double Needle chain stich (1) 11) Folders and works aids (2) 12) Die cutting (1) 13) Straight knife (2)	25 2 5 2 2 2 1 1 2 1 1 1 1 2		To meet the academic and industrial requirement

		14) Band knife (1) 15) Vacuum steam iron (1) 16) Fusing M/c (1) 17) Pattern tables (5) 18) Cutting Table (10) 19) Feed of the arm m/c (1) 20) Profile sewing M/c (1) 21) Automatic welt pocket attach(1) 22) CNC Cutter (1) 23) Pin table (1) 24) Auto Spreader (1) 25) Form finisher (1) 26) Pattern making software (5) 27) Digitizer (1) 28) Plotter (1) 29) Dummies (male20+20 female) 30) Computers (10) 31) Laptop (5) 32) Air conditioner (2) 33) Embroidery machines (10) 34) Sewing accessories (30) 35) Embroidery accessories (30) 36) LCD projector (2)	1 1 1 5 10 1 1 1 1 1 1 5 1 1 1 40 10 5 2 10 30 30 2	83.70	
4	Audio Visual Lab	1. LCD Projectors 2. Computers 3. LAP TOP 4. Headphone 5. Display Screen, Furniture & Fixtures for 60 capacity. 6. Audio and video recordings and educational software 7. Video conferencing system 8. Scanners 9. Language Library 10. Software for video editing and color visual aid system 11. LCD Computer System (10 Nos) 12. High resolution video camera	2 5 2 10 -- -- 1 2 -- 1 10 1	40.00	Essential to teach B.Tech . (CTT) & M.Tech. (CTM) students through virtual classroom and electronic study material like CD etc. for latest development and machine catalogues
5	Advance Textile Testing Lab	1. Tog meter 2. Sonometer 3. Yarn Bulkometer 4. Fabric softness tester 5. Fabric TIV tester 6. Alambata tester 7. Shirley friction tester 8. MVTR apparatus tester 9. Wicking tester	1 1 2 1 1 1 1 1 1	80.00	Requirement for industrial consultancy, testing and R&D activity.
6	Advance Textile Chemistry Lab	1) Lab dryer-1 2) Printing table-4 3) Screen making m/c-1 4) Vertical steamer lab model-1 5) Universal steamer -1 6) Two roller vertical padder-1 7) Two roller laboratory calendar-1 8) Jigger lab model -1 9) Beaker dyeing m/c lab model-2 10) Jet dyeing m/c lab model-1	1 4 1 1 1 1 1 1 2 1	54.00	Requirement for industrial consultancy, testing and R&D activity.

		11) Pad steam range lab model-1 12) Two arm dyeing for silk hank-1 13) Colour matching cabinet-2 14) Labcoater -1 15) High Temperature Laboratory Steamer-1 16) Auto Colour Dispenser Lab Model -1	1 1 2 1 1 1		
7	<u>Computer & IT Lab</u>	1. Computer & Software 2. Broadband 3. V-sat/ wifi system 4. Laptops 5. Lejar Printer 6. Scanner 7. Air Conditioner 8. LED Projector 9. Lab Renovation with insulated floor covering etc. and UPS System for 30 students capacity	30 1 1 30 1 2 4 2 1	50.00	Computer & internet facility to students & staffs
8	<u>Library:</u>	1) CC TV 2) Audio & Visual 3) Furniture Racks 4) Computer terminal 5) LAP Top 6) Library server 7) Microfish & Chip Reader 8) Photocopy Machine 9) UPS System 10) Air conditioner 11) Library software	5 1 30 7 1 1 1 1 1 2 1	40.00	Facilitate up-gradation of library and modern learning process
9	English & Foreign language lab	Includes software, Conference System, Projectors & Display Systems And furnitures & Fixtures	20.00	20.00	To take up essential language courses for the students soft skill development
10	Fashion Lab			50.00	
11	Soft Skill Lab	Accounting, Finance, Entrepreneurship Development Programme etc.		15.00	
12	Advanced CAD/CAM lab	To upgrade the institute with appropriate technology and software to take care of emerging need in all the fields of carpet and textile technology		205.00	
13	Advance spinning and Repto and Nonwoven 500 mm Solar Charkha etc.				
14	Upgradation of existing workshop (Spinning, dying, weaving etc.)				
15	Exclusive PG Lab		Research Equipment		
Total Rs.				802.70	

*The name and type of equipment(s) may be added or deleted at the time of execution depending on need at that time, however within estimated cost.

6.2 Estimated expenditure on project administration (including expenses on consultants, etc.) May be separately indicated.

Expenditure on project administration (including expenses on consultant) is Rs.457.38Lakhs (Details available in Non-recurring expenditure as per Annexure-III)

6.3 The basis of these cost estimates along with the reference dates for normative costing may be provided. The firmness of the estimate may be indicated along with the cost components that can vary, the factors that could cause the variation and the extent of the expected variation.

Estimate received as annexure-III to covering letter of the e-mail from LICI, Kanpur, the consultant of IICT approved by Government of India further added to attain the objective of Swach Bharat Mission, Greening, Rain Water Harvesting, Solar Energy Generation as directed higher authorities & emerging needs will be vetted/taken care of, by the construction consultant M/s Awas Evam Vikas Parishad, Varanasi

6.4 In case the project/ scheme involves payout of subsidy, the year wise expected outgo, up to the last year of payout, may be indicated.

Not applicable

6.5 In case the project/ scheme intends to create capital assets, employ specialized manpower or involves other activities that necessitate a Recurring Cost of Capital Expenditure (RCCE) (e.g., maintenance and upkeep costs of assets, salary costs of manpower, etc.) over the lifetime of the asset, such expenditures, on an annual basis, may be indicated in the project proposal.

Yes it is mentioned in Annexure-II (R-6)

6.6 It may also be stated whether the agency which would be assigned this legacy responsibility has been consulted and has agreed to bear the continuing recurring expenditure. (e.g., the State governments may need to incur the maintenance and upkeep costs of assets created under plan schemes.

Yes IICT is committed to maintain recurring expenditure other than Pay & Allowances 2021-22 onwards.

6.7 The cost towards salary/ fees/ emoluments of the project human resources as being proposed should be indicated (procedure for seeking approval of the human resource requirements is however detailed at para-7 below).

Cost towards Salary/Fees/Emoluments have been covered under Non plan.

6.8 The component of the costs mentioned at 6.1-6.7, that will be shared by the state governments may be indicated.

State Government has contributed in providing land approximately ~20 acres free of cost. IICT will continue to seek fund for Non-recurring and will to continue to get fund for Pay & Allowances under Non-plan as approved.

- 6.9 **In the event of fund transfer being made to State Govt. / local bodies or other organizations. "grants for creation of capital assets" may be indicated separately.**

There is no share from the State Government.

7 Project Human Resources

- 7.1 **Please indicate whether the nodal officer directly in charge of the project has been identified. Details about his status, past experience in executing similar projects and balance tenure left for steering the project may also be mentioned.**

Director, IICT is the Nodal Officer under the guidance of O/o the Development Commissioner (Handicrafts) Ministry of Textiles, Government of India.

- 7.2 **In case posts (permanent or temporary) are intended to be created, such proposal may be sent on file to personnel Division of Department of Expenditure separately. Such proposals may be sent only after the overall project proposal is recommended by the appropriate appraisal body (SFC, EFC, etc.).**

Manpower planning

Sanctioned v/s. Filled Posts status as on date

SI No.	Designation	Pay Scale	Mode Recruitment	No. of Sanctioned post	Status	
					Filled	Vacant
1.	Director	37400-67000 (AGP10000+Spl allowance 3000)	Direct	1	1	-
2.	Professor	37400-67000 (AGP 10000)	Direct	3	1	2
3.	Associate Professor	37400-67000 (AGP 9000)	Direct	5	3	2
4.	Assistant Professor	15600-39100 (AGP 6000)	Direct	7	7	-
5.	Librarian	15600-39100 (GP 6000)	Direct	1	1	-
	Sub Total (A)			17	13	4

Non Teaching Staff (Supporting Staff):

SI. No.	Designation	Pay Scale		No. of Sanctioned post	Status	
					Filled	Vacant
1.	Registrar	15600-39100 (GP 6600)	Direct	1	-	1
2.	ASO	15600-39100 (GP 5400)	Direct	1	1	-
3.	AO	15600-39100 (GP 5400)	Direct	1	1	-
4.	Phy. Lab I/C	9300-34800 (GP 4600)	Direct	1	1	-
5.	Chem Lab I/C	9300-34800 (GP 4600)	Direct	1	1	-
6.	Design Lab I/C	9300-34800 (GP 4600)	Direct	1	1	-
7.	Computer Lab I/c	9300-34800 (GP 4600)	Direct	1	-	1
8.	Workshop I/C	9300-34800 (GP 4600)	Direct	1	1	-

Sl. No.	Designation	Pay Scale		No. of Sanctioned post	Status	
					Filled	Vacant
9.	Lab Asstt.	9300-34800 (GP 4200)	Redeployment for 1No.	9	4	5
10.	Office Asstt.	9300-34800 (GP 4200)	Redeployment	4	-	4
11.	Admn. Asstt.	9300-34800 (GP 4200)	Direct	1	1	-
12.	Computer Lab Asstt.	9300-34800 (GP 4200)	Direct	1	1	-
13.	Library Asstt.	5200-20200 (GP)2400	Direct	1	1	-
	Sub Total (B)			24	13	11

Non Teaching staff (Skilled & Semi Skilled etc.):

Sl. No.	Designation	Pay Scale		No. of Sanctioned post	Status	
					Filled	Vacant
1.	Operator	5200-20200 (GP1900)	Direct	1	-	1
2.	Fitter	5200-20200 (GP1900)	Direct	2	-	2
3.	Cpt. I/C.	5200-20200 (GP2400)	Direct	1	-	1
4.	Dyeing Operator	5200-20200 (GP1900)	Direct	1	-	1
5.	Finishing Operator	5200-20200 (GP1900)	Direct	1	-	1
6.	Skilled Worker	5200-20200 (GP1800)	Direct	2	-	2
7.	Semi Skilled	5200-20200 (GP1800)	Direct	3	-	3
8.	LDC	5200-20200 (GP1900)	Redeployment	2	-	2
9.	Unskilled	5200-20200 (GP1800)	Direct	1	1	-
10.	Ele. Tech.	5200-20200 (GP1900)	Direct	1	1	-
11.	Driver	5200-20200 (GP1900)	Direct	1	1	-
	Sub Total (C)			16	3	13
	Grand Total (A+B+C)			57	29	28

Note:

* Dr. KK Goswami, Director, IICT himself is acting as one of the professor also as per decision of Executive Committee of IICT.

** To honour the decision taken by EFC Meeting dated 5th October 1998, IICT is exploring possibility of redeploying staff of DC(HC). As on date services of O/o. DC(HC) posted 10 staffs of different category are availed by IICT based on their capacity and hiring of services on contract basis through agency is also availed wherever possible. By doing this IICT is in a position to achieve the given target of Revenue Generation over Recurring Expenditure.

ADDITIONAL MANPOWER REQUIRED

Reference: M/Fin(Exp) I.D. No.1485/E.coord.I/2001 dated 27-01-2001.

EFC vide minutes of meeting dated 02-02-2007 resolved in point No.6 (clause no.4) as under:

“ For creation of proposed 26 posts a proposal may be sent to JS (Pers). However institute should also introduce the system of engaging guest faculty”.

Sanction for 9 New posts of Faculty as under:

- Professor 1 Posts
- Associate Professor.... 3 Posts
- Asst Professors..... 5 Posts

Sanction for 17 New posts of Non Teaching as under:

- Asstt. Librarian 01 Post (PB 3 PB3 15600-39100 with GP 5400)
- PS to Director 01 Post PB2 9300—34800 with GP 4800
- Asstt Lab Manager 04 Post PB2 9300—34800 with GP 4600
- Office Superintendent 01 Post PB2 9300—34800 with GP 4800
- Office Assistant... 03 Post PB2 9300—34800 with GP 4200
- Technical Asstt – 06 Posts PB2 9300—34800 with GP 4200
- Library Assistant... 01 Post PB2 9300—34800 with GP 4200

7.3 In case outsourcing of services or hiring of consultants is intended, brief details of the same may be indicated. It may also be certified that the relevant GFR provisions will be followed which engaging the agency/ consultant.

Details available in point No.7.2 (additional manpower required)

7.4 In case additional manpower requirement, please indicate the phased requirement over the project timeline (i.e. year-wise break-up of the manpower requirement)

Faculty requirement Phase wise:

Year	Total enrollment of student	Professor	Associate Professor	Asstt. Professor	Total*	Remarks
2016-17	281	2	4	13	19	19+1
2017-18	306	2	4	14	20	
2018-19	326	2	5	15	22	20+2
2019-20	331	2	5	15	22	
2020-21	336	2	5	15	22	
*1:15, faculty: students: and 1:2:6: Professor: Associate Professor: Assistant Professor						

Year wise additional requirement cadre wise faculty:

Year	Professor			Associate Professor			Asst. Professor			Total		
	Required	Existing Sanctioned	Additional requirement	Required	Existing Sanctioned	Additional requirement	Required	Existing Sanctioned	Additional requirement	Required	Existing Sanctioned	Additional requirement
2017-18	2	3	0	4	5	0	13	7	6	20	15	5
2018-19	2	3	0	4	5	0	15	7	8	22		7
2019-20	2	3	0	5	5	0	15	7	8	22		7
2020-21	2	3	0	5	5	0	15	7	8	22		7
*1:15, faculty: students: and 1:2:6: Professor: Associate Professor: Assistant Professor												

- As decided by EFC meeting dated 5th October, 1998, IICT shall continue saving significant expenditure by hiring of services on contract basis wherever possible against sanctioned post.
- IICT shall follow ACP as per AICTE rules for Teaching Staff and Govt. of India rules for other staffs in general.
- Those who have got desired qualification may be promoted in their respective cadre as proposed above through institute RR & DPC. All attempt shall be taken to utilize staff in pay scale equivalent to Assistant Professor and faculty also.
- Considering additional manpower required for Phase-II expansion has not yet been availed, the proposal of IICT to manage its activities with further expansion seeking only 20 additional posts may be considered as commitment for effective utilization of human potential. Moreover the effect outsourcing has been reflected in the requirement.

8. Project financing:

8.1 The source of financing for the project may be indicated. In case of project already included in the FYP, the specific earmarking may be mentioned. In case of any deviations from this quantum, the sponsoring agency may indicate how the gap will be addressed.

Through O/o Development Commissioner (HC), Ministry of Textiles, Government of India.

8.2 The availability of funds in the budget of the present year and the requirements projected may be mentioned. In case of any deviations, please indicate how the gap will be addressed.

The fund available in SFC of Phase-II amounting to Rs.494.94Lakhs. The estimated expenditure for F.Y. 2015-16 already have been submitted to O/o Development Commissioner (HC) vide letter No.1/DMC/DIR/GEN/10/IICT dt. 27-01-2015. The above mentioned said amount yet to be released by O/o Development Commissioner (HC) to Indian Institute of Carpet Technology (IICT).

8.3 If external sources are intended, the sponsoring agency may indicate whether such funds have been tied up. In case firm commitment is not available, alternate plans for arranging funds may be indicated.

Not applicable

8.4 Whether the funding requirements have been fully tied up with planning Commission may be indicated.

SFC/EFC involves Secretary (T) & Plan through O/o Development Commissioner (Handicrafts), Ministry of Textiles, Government of India.

9. Project viability:

9.1 In case of projects which have identified stream of financial returns, the financial internal rate of return may be calculated. The hurdle rate is considered at 12%.

FINANCIAL ANALYSIS

Analysis of phase I & II (EFC & SFC) :

Students Enrolled (ES):628,

Revenue Generated (RG):Rs 1779.19 lakh and Recurring expenditure (RE): Rs.3147lakhs

- Rs.163.92 yet to be released by O/o DC(HC) to IICT.

Fund allocated vide RCEIII (Rs. In Lakhs)			Over All	Target/ Bench mark	
Fund allocated/ utilized till	1998-99(1) ...,2015-2016(16) Nov.2001 onwards i.e. 2001-02				
Functional Year:36months from 5.10.1998					
SFC/EFC	I	II		-EFC Target.	
NON RECURRING	1320.00	1143	2463		
RECURRING(RE)	484.00	1356	1840		
Total	1804.00	2499*	4303		
No. of years involved	9	10	19		
Amount released to IICT (Avg. per annum)	200.44	249.90	226.47		
Amount released as % to yearly turnover (@ Rs. 3000 crore & 7000 crore for SFC I & II respectively)	0.067	0.036	0.046		
% RG/RE (1779.19/3147x100)	-	-	56.54		50.00 ¹
(a) RE/ES (RsLakh) (3147/628)	-	-	5.01		NA
(b) RG/ES (Rs Lakh) (1779.19/628)	-	-	2.83		NA
(a)-(b):Nett RE effect (5.01-2.83)	-	-	2.18		NA

Analysis of investment made in iict in trade turnover context

LEVEL OF TURNOVER IN EXPORT HOUSE	INDIRECT INVESTMENT	
	Rs. In lakhs	Rs. In thousands
Rs. 10 Lakhs	0.0046	0.46
Rs. 20 Lakhs	0.0092	0.92
Rs. 50 Lakhs	0.0230	2.30
Rs. 100 Lakhs	0.0460	4.60
Rs. 200 Lakhs	0.092	9.20
Rs. 500 Lakhs	0.230	23.00
Rs. 1000 Lakhs	0.460	46.00
Rs. 2000 Lakhs	0.920	92.00

INTERPRETATION OF THE ABOVE ANALYSIS

- Investment made so far in IICT clearly reveals that individual exporter even if reimbursed the amount equivalent to turnover cannot create at all any support system of its own to sustain in the global business environment.
- Output given by IICT so far clearly depicts commendable contribution to the industry and IICT deserves to be appreciated and acknowledged its contribution to the carpet, home textile and wool industry including designing sector. As per statistics IICT produced around 30000 outputs in last 14 years averaging around 2609 per year which works out to ~TEN (10) outputs every day on accumulation of activities in established portfolios: HRD, DCD, R&D, TSI .The average value of output even if kept at a reasonably lower level i.e. Rs. 0.50 lakh, IICT has given impact to the industry in general and society as whole to the level of ~1305 lakhs/annum. The impact in turn of pay back as a whole is 3 months only for every year at the current rate. (Average investment: Rs.307.36 lakhs /annum as on date vis-à-vis impact of 1305 lakhs).
- The future plan of IICT to add more disciplines and activities as well as doorstep service may be considered to be feasible.
- Considering additional activity, the exporters cum manufacturers covered under EPCH and IWMF/ WVEPC and Textile related export promotion council or manufacturing associations including AEPC will also get benefit.
- Keeping the investment @0.04%, (<0.046) and covering apparel sector also (assuming investment of 10 crore over 25000 crore total turnover)

the expansion plan supporting IICT through new phase (SFCIII) cumulative investment to go upto around Rs. 68.41 crore, which can sustain the Institute till 2020-21. The impact of investment and sustainability plan (partly self-sufficient with respect to recurring expenditure) as projected in the roadmap is enclosed herewith (**Annexed-VI**)for consideration of competent authorities .The document depicts a healthy picture which is expected to be acceptable by all concerned to sanction this budget estimate.

Impact made to the sector through Phase I & II: EFC & SFC:

The institute has been able to serve the sector through following actions:

- Taking decisions through meetings of Executive Committee
- Laying of 12 Annual Reports in both the houses of parliament (Copy enclosed)

- The institute has been able to be a pro-industry through formation of Kaleen Bandhu comprises of members from the industry who meet and discuss time to time to take up agenda of mutual interest.
- The institute has been able to come out with its Directories. 3 such directories has been circulated to all concerned with focus on strengthening of industry-institute interface. (Copies of are enclosed)
- The institute has been able to develop academic community/ culture as evident from various publications which includes publication entitled ‘Advances in Carpet Manufacture published by M/S Woodhead Publishing, UK.
- Commercialization of R&D:
- The institute has started guiding Research scholars those who are pursuing for their doctorate degree pertain to the field of wool/ carpet/ textiles.

9.2 In case of projects where financial returns are not readily quantifiable (typically social development projects), the economic rate of return may be estimated.

Analysis of SFC III proposed

Analysis of Investment (Rs. in lakhs)

Total investment for 5 Years (2016-17 to 2020-21)	5423.36
Per Year Investment at current rate (5423/5)	1084.67
<i>Turnover (Carpet +Home Textiles + Wool & Woolens) at current rate in approximation</i>	20000
% to Sector's Turnover	0.054

Need for Phase- III : SFC /EFC

In phase III for continuation of existing activities with existing sanctioned strength of faculty and staff investment has been kept limited to Rs. 68.41 crore only considering the need for continuation. The viability of continuation of existing activities has been reinforced by conducting training programme under ISDS and CHCDS.

10. Project implementation and monitoring:

10.1 The administrative structure for implementing the project may be stated. In case new structures/ entities etc. is by and large to be avoided. In case new structure are intended to be created for administering the scheme. The details of such structures and specific justification for the same may be provided. Such new structure should be processed only if it has been established after due analysis, that existing structures cannot be levered for the proposed / additional work.

Need for Expansion:

The need has been felt by University, Industry and management to make the institute viable and long-lasting as evident from documents annexed. The addition of M.Tech in Carpet & Textile

Management (CTM) to the existing field will increase the scope of service. The export turnover of the sectors together is not less than Rs. 25000 crores (3500 crores for Carpet, 4000 for Home Textiles & 17500 for rest). There is no such institute which can serve the need of the sectors in portfolios like HRD, DCD, R&D and TSI. Therefore, need for expansion of IICT is absolutely justified and could be the right decision on the part of Govt. of India.

Proposed Strategy:

The proposed strategy for implementation of different issues, which mentioned above includes initiation of

- Addition of relevant disciplines like M.Tech in Carpet & Textile Management (CTM).
- Extension of R&D to cover the need of the academic and industry.
- To act over Strength, Weakness, Opportunity & Threats (SWOT)
- To serve more sectors like Fashion and Apparel besides wool, home textiles including Handmade and Machine made Carpet & designing.

Therefore, their course content, curriculum, fee structure, student selection mechanism etc. for the relevant disciplines and strategy /proposal for other activities need to be in place as has been included.

Details available in point No.3

10.2 A flow chart for the intended fund flow mechanism may be indicated. Funds flows for all schemes/ projects in states should ordinarily be through the State Government.

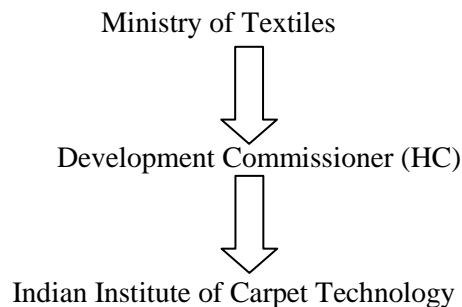

The Ministry of Textile (MOT) Government of India will release funds to the Indian Institute of Carpet Technology (IICT) as per approval of the scheme by the competent authority, availability of the budget, requisition of IICT and depending upon progress of utilization of funds release from time to time under the scheme.

10.3 The monitoring framework for the project/ scheme may be indicated. The Arrangements for audit of the project may also be stated.

The monitoring of the project will be done by the O/o Development Commissioner (Handicrafts), Ministry of Textiles, Government of India. The account will be audited by Internal & Statutory auditor.

11. Project/ Scheme sensitivities:

11.1 Any foreseeable constraints/ uncertainties which can affect the technical design, costing and implementation of the project may be indicated.

Delay in sanction release of fund & execution.

11.2 The likely impact of these constraints/ uncertainties on the project parameters may be stated. In particular, the sensitivity of the project cost, project schedule and project viability towards the possible constraints/ uncertainties may be mentioned.

The fund allocation for the purpose will get utilized.

12. Project period:

12.1 The expected date of project completion may be stated. This should be realistic and supported with PERT Chart of the important activities, with a critical path analysis, identifying the main constraints.

Project may be completed within time frame as above mentioned point no.1.3, subject to release/availability of fund.

12.2 The project closure date should be also indicated beyond which further government support/ disbursement of funds will not be required.

The implementation of the scheme will be for the XII Plan which will be over in 2018-19.

12.3 A time line for the project deliverables (i.e. measurable deliverables phased year-wise) may be included.

Summary of Expenditure in Rs. lakhs from 2016-17 to 2020-21

Summary of Expenditure in Rs. lakhs from 2016-17 to 2020-21

Summary of activity	Non Recurring	Recurring	Total	Remarks
Continuation of existing B.Tech (CTT with specialization), M.Tech. in Carpet & Textile Management (CTM) and other portfolios	5423.36	1417.87	6841.23	<ul style="list-style-type: none">• Details of Non-recurring expenditure as per Annexure-V• Details of Recurring expenditure as per Annexure-VI

13.RCE proposals:

13.1 Details of physical progress achieved and expenditure incurred and commitment made so far may be given.

Not applicable

13.2 Date of latest approved, revised and proposed completion schedule of the project along with time overrun and reasons there of may be elaborated.

Not applicable

13.3 Item-wise cost variance between approved (latest) cost and revised cost as propose may be given.

Not applicable

13.4 Reasons of increase in cost may be given in the following manner

- (a) Price Escalation**
- (b) foreign Exchange variation**
- (c) Statutory levies**
- (d) Change in Scope**
- (e) Addition/ deletion**
- (f) Under- estimation**
- (g) Others (to be specified)**

Not Applicable

13.5 The underlying justification for increases in cost due to various factors may be explained.

Not Applicable

13.6 Effect of revision in capital cost estimates on cost of production and profitability/ viability with reference to earlier approved capital cost of the project

Not Applicable

13.7 Report of Standing Committee to fix the responsibility for cost and time overrun along with action taken report on its recommendations may be appended with the EFC/ PIB memo.

Not Applicable

Conclusion:

Over a decade, IICT contributed through its established portfolios particularly in HRD & R&D to a great extent to meet the existing gap. RFD of the institute is the expression of commitment for serving the trade. Further, IICT is committed to support the trade to take it to new heights in all relevant fronts.

Acknowledgement

The Director, IICT & his team wish to record their sincere gratitude to Dr K. Gopal, I.A.S., Development Commissioner (Handicrafts) & Chairman IICT, Shri P.K.Thakur, Director (Handicrafts) & Vice-Chairman, E.C. Members and all stakeholders for their kind & continuous support which enabled the institute to reach mentioned height.

Introduction in prospective:

The IICT after getting started in November 2001 could grow as desired to make it a Center-of-Excellence and endeavors made it to reach International Standard. However, achieving further excellence is in process. The further expansion of IICT became imperative due to following reasons:

- Optimum utilization of resource
- Addition of relevant disciplines like M.Tech in Textile Management
- Extension of R&D to cover the need of the academic and industry.
- To act over Strength, Weakness, Opportunity & Threats (SWOT)
- To serve more sectors like Fashion and Apparel besides wool, home textiles including Handmade and Machine made Carpet & designing.

FINAL CONCLUSION:

1.The compliance to the resolution of EC dated 13.10.2012 has been made to facilitate decision whether to go for additional activity or not although continuation existing activity is a pre requisite.

2.Honble Vice Chancellor of the University was apprised about the expansion plan and his opinion in the form of message on the occasion of Institute Day celebrated on 01.11.2012 is reproduced below

Dr. R.K. Khandal
Vice Chancellor



GAUTAM BUDDH TECHNICAL UNIVERSITY
(Formerly Uttar Pradesh Technical University)
I.E.T. Campus, Sitapur Road, Lucknow-226 021 (U.P.)

Dated : 01.11.2012

Sub.: Celebrations of 12th Institute Day on 1st Nov. 2012 by IICT; Our Message

Dear Prof. Goswami,

It is a matter of great pleasure to note that the faculty and students of IICT would be celebrating their Institute day, today. It would have been my honour to be personally present amongst you on this occasion but I am sorry to say that I would not be able to make it in spite of my keen desire to do so. Due to certain unforeseen reasons, I have to beg your pardon at the last moment.

In order to register our appreciation for your efforts, I would like to express that:

- (i) The social activities, such as 'Blood Donation', 'Creating awareness of Care & Fare School Children from carpet weavers' families etc. by students of IICT, are commendable.
- (ii) Director IICT and his whole team deserve kudos for the praise-worthy record of academic performance of the students. University acknowledges it as a remarkable achievement of IICT.
- (iii) The demand of change of name from "Indian Institute of Carpet Technology (IICT)" to Indian Institute of Carpet and Textile Technology (IICTT) seems relevant and worth considering.
- (iv) The plans of IICT to start new courses i.g. 'B.Tech in Fashion and Apparel Technology' and 'M.Tech in Textile Management' are appreciated. G.B. Technical University will provide all possible support necessary to affiliate these courses, in public interest.
- (v) Considering the research and academic potential, G.B.T.U. would encourage IICT for Pre-Ph.D mentoring/examination centre to promote scholastic activity.
- (vi) G.B. Technical University will extend all possible support for students and faculty.

With the above statements, I wish IICT -'An Institute with difference' functioning under the dynamic leadership and administrative control of Development Commissioner (Handicrafts) Ministry of Textiles, Govt. of India, a huge success in all its endeavours. Under the stewardship of Prof. Goswami, I have no doubt that IICT will certainly become a true international academic/research/referral centre in textiles.

I wish 12th Institute day a success and many happy returns of the day.

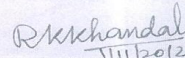
(Dr. R.K. Khandal)
Vice Chancellor

Prof. (Dr.) K.K. Goswami
Director
Indian Institute of Carpet Technology (IICT)
Chauri Road, Bhadohi-221401

Phones : (Off.): +91-522-2732194, (Fax): +91-522-2732189, (Res.): +91-522-2731631
Email : rkhandal@uptu.ac.in, vc@uptu.ac.in Website: www.uptu.ac.in

5. Further Feasibility Study was conducted, which is as under:

1. B.Tech. Course in Fashion and Apparel Technology &
2. M.Tech. in Textile Management.

Note: Detailed report is annexed (Annexure-XI).

6. In the meantime, competent authority has sanctioned a project entitled "Feasibility Study on up-gradation of IICT, Bhadohi to a national level Textile Institute" under R&D scheme based on a VIP reference as under:

वीरेन्द्र सिंह
संसद सदस्य
(लोक सभा)



आवास- स्वदेशी आश्रम
इन्दिरा मिल घोराहा, चौरी रोड,
जनपद- सन्त रविदास नगर भदोही
पिन - 221401, उत्तर प्रदेश
मो० नं० 09452105009

पत्रांक : 00089/78BDH/MP

दिनांक : 27 अगस्त 2014

आदरणीय,

विकास आयुक्त हस्तशिल्प एवं अध्यक्ष आईआईसीटी, भदोही
कार्यालय विकास आयुक्त हस्तशिल्प,
पश्चिम खण्ड-7, आर.के. पुरम
नई दिल्ली-110066

विषय: राष्ट्रहित एवं जनहित में आईआईसीटी, भदोही की उपयोगिता के सम्बन्ध में।

मैं हाल ही में आईआईसीटी, भदोही में दौरा किया यहाँ पर स्थापित जो विश्वस्तरीय सुविधाएँ बनायी गयी वह बहुत ही सराहनीय हैं मैंने आईआईसीटी, के अध्यापकों/अधिकारियों एवं स्टाफ तथा उद्योग जगत के लोगों से गहन बातचीत एवं आत्मनिरीक्षण के पश्चात् निम्न बातों का उल्लेख करना चाहता हूँ:-

1. आईआईसीटी, का विस्तार किया जा सकता है।
2. आईआईसीटी, का विस्तार डिम्ब विश्वविद्यालय के स्तर पर इण्डियन स्कूल ऑफ टेक्सटाइल के रूप में किया जाय।
3. इस विश्वविद्यालय में टेक्सटाइल के हर क्षेत्र के साथ-साथ कम्प्यूटर विज्ञान प्रबन्धन के क्षेत्र का भी समावेश रहेगा जिससे इण्डियन स्कूल ऑफ टेक्सटाइल पूर्ण एवं प्रभावशाली तरीके से कार्य करेगा।
4. इसके अलावा सम्बन्धित क्षेत्र के सभी व्यवसायिक प्रशिक्षण की भी सुविधा आईआईसीटी, भदोही में बनायी जाय जिससे अधिक से अधिक योग्य प्रशिक्षित व्यक्तियों को उद्योग जगत को दिया जाय।

अतः आपसे अपेक्षा की जाती है उपरोक्त विषय पर आप अपने सम्बन्धित अधिकारी को निर्देशित करें ताकि एक डी.पी.आर. (Detailed Project Report) आपके सक्षम आवश्यक कार्यवाही हेतु प्रस्तुत किया जाय तथा उसकी एक प्रति मुझे भी अग्रसारित किया जाय ताकि आगे की कार्यवाही हेतु माननीय वरन् मंत्री भारत सरकार से मिलकर आवश्यक कार्यवाही सुनिश्चित किया जाय। इस सम्बन्ध में हमारा पूरा सहयोग आवश्यकतानुसार समय-समय पर प्राप्त होता रहेगा।

भवदीय

वीरेन्द्र सिंह
सांसद भदोही

22/10
27/8/14

H.O.O/A 80/A.O/ DMC (K.S)

TO put up/whilere fana

27/8/14

27/8/14

The proposed expansion SFC-III in hand and above study may be integrated for the DPR. The experts engaged are invited in the presentation to be made on 23-11-2015 for participation.

ASO/AO
Forma No. DMC
to record the
up. J
3/11/15

Minutes of the meeting under the chairmanship of DC(HC)/Chairman IICT on 23rd November, 2015 at 530 PM with regard to the DPR for EFC/SFC under futuristic plan for expansion of IICT under Phase-III.

The list of participants:

1. Shri P.K. Thakur, Director, Handicrafts and vice chairman IICT
2. DR. KK Goswami, Director, IICT, Bhadohi

1. Initiating the discussion, Director IICT apprised about background of IICT as well about earlier EFC under Phase I & II, in the context of expansion.
2. Director IICT submitted the DPR and PowerPoint presentation vide letter number, 3/5/IICT/SFC/EFC/2015-16 dated 23-11-2015.
3. DC Handicrafts, expressed concern about employability of M-Tech (Carpet & Textile Management) pass out of the proposed program.
4. Integration of elements like entrepreneurship, fashion, information technology, accounting, finance, management including performance and project management in the existing B.Tech course was suggested.
5. The expansion of IICT as per DPR was accepted in principle.
6. For explaining the feasibility study report, the expert concerned Mr. KK Bajpai, was also present.
7. Introduction of M.Tech (Carpet & Textile Management) ^{may be proposed only} was suggested after identifying the industry relevance of the program.
8. It was advised to work on a proposed curriculum / syllabus for the proposed M.Tech (Carpet & Textile Management) program.
9. On the above background modification has been suggested integrating with the feasibility study titled as "Upgradation of IICT Bhadohi, to a national level textile institute" of university level under R&D scheme of o/o DCHC involving experts as approved by EC.

The meeting ended with vote of thanks to the chair.

(Alok Kumar)
DC(HC), Chairman IICT

(P.K. Thakur)
Director (HC), Vice Chairman IICT

DR. KK. Goswami
Director, IICT

DAK-44
DATE 2/12/15

MINUTES OF 53rd EXECUTIVE COMMITTEE (EC) MEETING OF INDIAN INSTITUTE OF CARPET TECHNOLOGY (IICT), BHADOHI HELD ON 15.03.2016 AT 03.00 PM IN THE COMMITTEE ROOM OF O/O DC(HC), NEW DELHI.

The following members were present:

1. Dr. K. Gopal, IAS, Development Commissioner (Handicrafts) & Chairman, IICT.
2. Shri P.K.Thakur, Director (Handicrafts) Vice-Chairman, IICT.
3. Shri S.K.Gupta, ED, CEPC, New Delhi
4. Shri Bholanath Baranwal, BIL, G.T. Road Khachhawan, Varanasi
5. Dr.Arindam Basu, DG, NITRA,Ghaziabad
6. Shri G.S.Parashar, Dy.Director, Textile' Committee, New Delhi - Nominee-Secretary, TC,Mumbai
7. Shri Sanjay Singh, Jaipur Rugs, Jaipur-Nominee
8. Shri A.K.Kureel, Sr. A.D.(Institutional), O/o DC(HC), New Delhi
9. Dr. S.K.Pal, Professor, CPC & Registrar I/c, IICT-Director's Nominee
10. Shri R.K.Malik, Asso. Professor & Dean, IICT-Director's Nominee.
11. Prof.(Dr) K.K.Goswami, Director & Member Secretary, IICT

Leave of absence:

Rest other members of Executive Committee of IICT who could not attend.

1. Agenda Item No. 1. Welcome to Members

Chairman, IICT welcomed the members present in the meeting and thanked them for sparing their valuable time to attend the meeting. However, Director, IICT introduced the members to Chairman, IICT before starting the proceeding of meeting.

2. Agenda Item No. 2. Confirmation of Minutes

The committee confirmed the minutes of the 52nd EC Meeting held on 01.11.2015.

3.0 Agenda Item No 3. Action Taken Report on decision of EC/SGM Meetings up to dates:

The committee noted the action taken report on the decision of the committee and appreciated action taken & efforts made. However, the following observations on certain points have been made.

3.1 Futuristic Plan (SFC/EFC):

The committee noted the status of revised DPR for SFC as well "Feasibility study on up-gradation of IICT,Bhadohi to a national level Textile Institute" of university level in hand. The modified DPR integrated with feasibility study report be submitted by March end this year for subsequent necessary administrative action.

(K Gopal)
Chairman

(P.K.Thakur)
Vice-Chairman

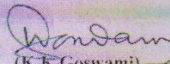
(K.K.Goswami)
Member Secretary

3.2 Conduction of Training under various projects/schemes including CHCDS/ ISDS.

The committee noted the progress and status. The issue of disparity in stipend to trainees between IICT and CEPC run programme was also discussed. Therefore, the committee desired that in the next phase of training programme for 1500 trainees under CHCDS scheme, the stipend to be paid to trainees should be at par.

3.3 Inverter Procurement and distribution:

The committee noted the status and advised IICT Cell of o/o DC(HC) and IICT to make necessary follow up with IFW.

3.4 Extension for Phase-II EFC:

The committee noted status and advised IICT to follow up with IFW.

3.5 IICT industry interface: The committee was of the opinion to have strong synergy amongst IICT, Industry and CEPC so that adequate and qualitative national as well as international internship/placement for all intending students can take place. IICT to collect the career exhibition calendar for National and International level, organised by CEPC and submit a proposal for participation by IICT students/faculty/staffs to Director (HC) for subsequent proceeding.

3.6 Progress of on going projects: The committee noted the status as under;

IICT to submit UC for all completed projects by March 2016 end.

IICT sought extension for 9 R&D projects related to new technologies / studies which will be completed well before end of 2016-17.

The committee advised IICT to give scheme wise PPT presentation for the completed projects in front of Director(HC) and AD concerned at the earliest as convenient.

3.7 Service Rule including TA-DA & Staff Promotion Schemes-MACP/CAS: The committee noted the status. The IICT Cell o/o DC(HC) to communicate decision/approval.

3.8 Reduction on Expenditure on use of Gen-Set. : The committee has been apprised about the status that BIDA CEO will take up the matter in its next board meeting. However, committee desired that IICT to explore installation of solar system to comply the advice of ASFA during his visit to IICT-Bhadoli and submit a proposal in accordance for administrative decision.

3.9 Extension centre of IICT: As regard support to RCWPDS, the Satellite Centre of IICT at Jaipur in this regard a proposal to be submitted to seek approval of chairman on file.

3.10 Recruitment for filling up of posts of IICT: The Committee noted the status. IICT

to follow up with IICT Cell O/o DC(HC) to expedite the release of advertisement in employment news and in national dailies.

3.11 Procurement: The committee noted the status and emphasized the requirement. The decision of competent authority to be communicated by IICT Cell of O/o DC(HC).

(K.Gopal)
Chairman

(P.K.Thakur)
Vice-Chairman

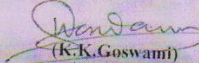
(K.K.Goswami)
Member Secretary

3.12 **Expansion of IICT:** The committee noted the status about construction work in the new campus managed by Awasthi Vikash Parishad, Varanasi a UP Govt agency.

3.13 **Change in Admission criteria for Direct Admission in B.Tech 1st year against vacant seats:**

The committee noted the detailed study and interpretation in this regard. In view of the interpretation the committee accepted that the existing admission procedure to continue instead of conducting exam for direct admission.

3.14 **Progress Report:** The committee noted & appreciated the progress of Physical, Financial sponsored projects and RFD.

3.15 **Annual Action Plan and budget estimate for the FY 2016-17:** The committee noted the plan and outlay including for continued non plan support for pay and allowances in process. Recurring expenditure other than pay and allowances to be met from revenue fund. Non recurring expenditure to be carried out only after administrative/SFC approval.

4.0 Agenda discussed and decision taken:

(i) **Cooperation of IICT Bhadohi to handover the Carpet Backing project to new S.P.V.:** The EC noted the fact sheet in this regard and resolved again that the decision of EC of IICT conveyed vide letter from DC(HC) stands correct and needs no further revision. After the issue of handover/takeover is over, SPV may approach IICT for any service for their quality management for which IICT to respond as per its policy, capability and tariff schedule without any liability.

(ii) **Annual Maintenance Contract (AMC):** The committee noted the requirement of maintenance of plant and equipments to keep them always in order. The committee further desired the maintenance of campus including building, road, house keeping sanitary, drainage and sewerage etc also to be covered under AMC. A detailed proposal with background, justification and financial implication be submitted for taking administrative approval of Chairman, IICT.

5.0 Other matter discussed and decided:

Repositioning of IICT: The Chairman, IICT appreciated that IICT is doing well but there should be no space for complacency. Therefore, it was specifically desired that IICT to prepare a road map in a manner to reposition itself to meet the emergent needs like capacity building, visionary approach and promotional activities like Mobile labs, Entrepreneurship development Programme (EDP) for artisans & youth for deriving demographic dividend, outreach across the country, true referral centre as a repository for carpet sector in particular and submit to Chairman, IICT.

Meeting ended with vote of thanks to the chair.

(K Gopal)
Chairman

(P.K.Thakur)
Vice-Chairman

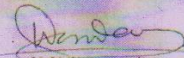
(K.K.Goswami)
Member Secretary

Page 3 of 3

ANNEXURES

S. No.	Contents	Annexure No.
1	Resolution in SGM's	I
2	Minutes of meeting IICT Staffs on Phase III	II
3	LIC's email on NR Budget Estimate and Master Plan	III
4	Minutes of EFC & SFC	IV
5	Break up of target revenue (RG)	V
6	Proposed recurring expenditure (RE)	VI
7	Annual Report for 2014-15	VII
8	Kaleen Bandhu Brochure	VIII
9	Publications on handmade carpets: Socio Economic	IX
10	Publication by AATCC on Carpet pile stability	X
11	Feasibility Study Report	XI

To,
Development Commissioner (Handicrafts)
O/o DC (HC), West Block No.-VII
R.K.Puram,
New Delhi-110 066

Subject: Modified DPR for EFC/SFC for continuation of existing activities of IICT, Bhadohi-reg.

Sir,

This refers to above mentioned subject, in this regard, EC of IICT resolved vide meeting dated as under-

Meeting dated 13-06-2014:

“In view of consideration of coverage of Pay & Allowances under Non Plan for IICT by the Ministry of Textiles, DC (HC) desired IICT to assist IICT Cell of O/o DC(HC) in formulation of the modified EFC document excluding the Pay & Allowances, for subsequent action at the earliest.” (copy of minute enclosed)

Meeting dated 08-09-2015:

“The committee advised IICT Cell of O/o DC(HC)_ to return the DPR to Director, IICT with the advised to submit revised DPR incorporating additional emerging inputs. Further Chairman, IICT advised to complete “ Feasibility study of Up-gradation of IICT to national level Textile Institute” of University level at earliest following a roadmap engaging relevant experts with due intimation to Vice-Chairman, IICT.” (copy of minute enclosed)

Further to above O/o Development Commissioner (HC) vide letter No.I-11020/14/2015-16/IICT/444 dated 09-11-2015, directed by the Development Commisisoner (HC) to make lucid presentation on 23-11-2015 at 3 PM.

In compliance to above, enclosed please find the fresh DPR (duly filled in EFC/SFC format/memorandum). However, PPT presentation is proposed to be made on 23-11-2015 in the O/o Development Commissioner (HC)

Submitted for taking necessary action for proposed expansion programme including continuation of existing activities in respect of Indian Institute of Carpet Technology, Bhadohi.

Yours faithfully

**Prof. (Dr) K.K.Goswami
Director, IICT**